

LR101 SERIES

System Board User's Manual

935-LR1011-000G
A14200015

Copyright

This publication contains information that is protected by copyright. No part of it may be reproduced in any form or by any means or used to make any transformation/adaptation without the prior written permission from the copyright holders.

This publication is provided for informational purposes only. The manufacturer makes no representations or warranties with respect to the contents or use of this manual and specifically disclaims any express or implied warranties of merchantability or fitness for any particular purpose. The user will assume the entire risk of the use or the results of the use of this document. Further, the manufacturer reserves the right to revise this publication and make changes to its contents at any time, without obligation to notify any person or entity of such revisions or changes.

© 2010. All Rights Reserved.

Trademarks

Windows® 2000 and Windows® XP are registered trademarks of Microsoft Corporation. Award is a registered trademark of Award Software, Inc. Other trademarks and registered trademarks of products appearing in this manual are the properties of their respective holders.

FCC and DOC Statement on Class B

This equipment has been tested and found to comply with the limits for a Class B digital device, pursuant to Part 15 of the FCC rules. These limits are designed to provide reasonable protection against harmful interference when the equipment is operated in a residential installation. This equipment generates, uses and can radiate radio frequency energy and, if not installed and used in accordance with the instruction manual, may cause harmful interference to radio communications. However, there is no guarantee that interference will not occur in a particular installation. If this equipment does cause harmful interference to radio or television reception, which can be determined by turning the equipment off and on, the user is encouraged to try to correct the interference by one or more of the following measures:

- Reorient or relocate the receiving antenna.
- Increase the separation between the equipment and the receiver.
- Connect the equipment into an outlet on a circuit different from that to which the receiver is connected.
- Consult the dealer or an experienced radio TV technician for help.

Notice:

1. The changes or modifications not expressly approved by the party responsible for compliance could void the user's authority to operate the equipment.
2. Shielded interface cables must be used in order to comply with the emission limits.

Table of Contents

Copyright.....	2
Trademarks.....	2
FCC and DOC Statement on Class B.....	3
About this Manual.....	6
Warranty.....	6
Static Electricity Precautions.....	7
Safety Measures.....	7
About the Package.....	8
Before Using the System Board.....	8
Chapter 1 - Introduction.....	9
Specifications.....	9
Features.....	12
Chapter 2 - Hardware Installation.....	16
System Board Layout.....	16
System Memory.....	17
Installing the DIM Module.....	18
Jumper Settings.....	20
Clear CMOS Data.....	20
PS/2 Power Select.....	21
USB Power Select.....	22
Panel Power Select.....	23
CompactFlash Card Setting.....	24
COM 3 RS232/RS422/RS485 Select.....	25
COM 1 RS232/Power Select.....	26
HDMI/DVI Select.....	27
Power-on Select.....	28
Rear Panel I/O Ports.....	29
DC-in 12V.....	30
VGA Port.....	31
HDMI Port.....	32
DVI-I Port.....	33
USB Ports.....	34
RJ45 LAN Ports.....	36
Audio.....	37

I/O Connectors.....	38
KB/Mouse Connector	38
CD-in Internal Audio Connector	40
S/PDIF Connector.....	41
LVDS LCD Panel Connector and LCD/Inverter Power Connector.....	42
Digital I/O Connector.....	44
SATA (Serial ATA) Connectors	45
IDE Connector	46
Cooling Fan Connectors.....	48
Chassis Intrusion Connector	49
Peripheral Power Connector	50
LEDs.....	51
Front Panel Connectors.....	52
Expansion Slots	53
Battery	54
CompactFlash Socket.....	55
Chapter 3 - BIOS Setup.....	56
Overview	56
AMI BIOS Setup Utility	58
Main	58
Advanced	59
PCI/PnP.....	74
Boot	76
Security	81
Chipset	87
Exit	91
Updating the BIOS.....	94
Chapter 4 - Supported Software	95
Appendix A - NLITE and AHCI Installation Guide	142
Appendix B - Watchdog Timer.....	154
Appendix C - System Error Message.....	157
Appendix D - Troubleshooting.....	159

About this Manual

An electronic file of this manual is included in the CD. To view the user's manual in the CD, insert the CD into a CD-ROM drive. The autorun screen (Main Board Utility CD) will appear. Click "User's Manual" on the main menu.

Warranty

1. Warranty does not cover damages or failures that arised from misuse of the product, inability to use the product, unauthorized replacement or alteration of components and product specifications.
2. The warranty is void if the product has been subjected to physical abuse, improper installation, modification, accidents or unauthorized repair of the product.
3. Unless otherwise instructed in this user's manual, the user may not, under any circumstances, attempt to perform service, adjustments or repairs on the product, whether in or out of warranty. It must be returned to the purchase point, factory or authorized service agency for all such work.
4. We will not be liable for any indirect, special, incidental or consequential damages to the product that has been modified or altered.

Static Electricity Precautions

It is quite easy to inadvertently damage your PC, system board, components or devices even before installing them in your system unit. Static electrical discharge can damage computer components without causing any signs of physical damage. You must take extra care in handling them to ensure against electrostatic build-up.

1. To prevent electrostatic build-up, leave the system board in its anti-static bag until you are ready to install it.
2. Wear an antistatic wrist strap.
3. Do all preparation work on a static-free surface.
4. Hold the device only by its edges. Be careful not to touch any of the components, contacts or connections.
5. Avoid touching the pins or contacts on all modules and connectors. Hold modules or connectors by their ends.



Important:

Electrostatic discharge (ESD) can damage your processor, disk drive and other components. Perform the upgrade instruction procedures described at an ESD workstation only. If such a station is not available, you can provide some ESD protection by wearing an antistatic wrist strap and attaching it to a metal part of the system chassis. If a wrist strap is unavailable, establish and maintain contact with the system chassis throughout any procedures requiring ESD protection.

Safety Measures

To avoid damage to the system:

- Use the correct AC input voltage range.

To reduce the risk of electric shock:

- Unplug the power cord before removing the system chassis cover for installation or servicing. After installation or servicing, cover the system chassis before plugging the power cord.

Battery:

- Danger of explosion if battery incorrectly replaced.
- Replace only with the same or equivalent type recommend by the manufacturer.
- Dispose of used batteries according to local ordinance.

About the Package

The system board package contains the following items. If any of these items are missing or damaged, please contact your dealer or sales representative for assistance.

- ☑ One system board
- ☑ One IDE cable
- ☑ One USB cable
- ☑ One Serial ATA cable
- ☑ One Serial ATA power cable
- ☑ One PS/2 cable
- ☑ One bracket mounted with a COM port
- ☑ One I/O shield
- ☑ One CD
- ☑ One QR (Quick Reference)

The system board and accessories in the package may not come similar to the information listed above. This may differ in accordance to the sales region or models in which it was sold. For more information about the standard package in your region, please contact your dealer or sales representative.

Before Using the System Board

Before using the system board, prepare basic system components.

If you are installing the system board in a new system, you will need at least the following internal components.

- Memory module
- Storage devices such as hard disk drive, CD-ROM, etc.

You will also need external system peripherals you intend to use which will normally include at least a keyboard, a mouse and a video display monitor.

Chapter 1 - Introduction

Specifications

Processor	<ul style="list-style-type: none">• Intel® Atom™ D510 (Dual Core Pineview-D) - LR101-B16D• Intel® Atom™ D410 (Single Core Pineview-D) - LR101-B16S• Intel® Atom™ N450 (Single Core Pineview-M) - LR101-B16M• On die 2 x 512KB (LR101-B16D), 1 x 512KB (LR101-B16S / LR101-B16M); 8-way L2 cache• C0 and C1 C-states - LR101-B16D/LR101-B16S• C0/C1(E)/C2(E)/C4(E) C-states - LR101-B16M• 1.6GHz core frequency, 1.10V voltage• IA 32-bit and Intel® 64 architecture• Micro-FCBGA8 packaging technologies
Southbridge	<ul style="list-style-type: none">• Intel® ICH8M I/O Controller Hub
System Memory	<ul style="list-style-type: none">• Two 200-pin SODIMM sockets• 667MHz DDR2 SDRAM only• Single channel memory interface• Maximum of 2GB system memory<ul style="list-style-type: none">- Maximum of 1GB per SODIMM socket• Supports x16 devices
Expansion Slots	<ul style="list-style-type: none">• 1 PCI Express x1 slot• 1 PCI slot
Graphics	<p>LR101-B16D/LR101-B16S</p> <ul style="list-style-type: none">• Integrated Intel Gen3.5<ul style="list-style-type: none">- Contains a refresh of the 3rd generation graphics core• 400MHz render clock frequency• Display ports: LVDS and VGA<ul style="list-style-type: none">- Integrated single LVDS channel supports resolution up to 1366x768, 18bpp- Analog VGA display output up to resolution 2048x1536 @ 60Hz• DirectX 9 compliant Pixel Shader 2.0 <p>LR101-B16M</p> <ul style="list-style-type: none">• Integrated Intel Gen3.5<ul style="list-style-type: none">- Contains a refresh of the 3rd generation graphics core• 200MHz render clock frequency• Display ports: LVDS and VGA<ul style="list-style-type: none">- Integrated single LVDS channel supports resolution up to 1280x800 or 1366x768- Analog VGA display output up to resolution 1400x1050 @ 60Hz• DirectX 9 compliant Pixel Shader 2.0

S3 Graphics	<ul style="list-style-type: none"> • S3 Graphics Chrome® 435 ULP • 500MHz core clock • Four DDR2 512Mbit 32Mx16 memory • Display ports: 2 DVI-I and 1 HDMI <ul style="list-style-type: none"> - Does not support multiple displays using HDMI and 2 DVI-I at the same time. For dual display, use the bottom DVI-I with either the top DVI-I or HDMI. • 64-bit memory bus width • Dual rank 256MB maximum memory • H.264/AVC - MPEG-4 Advanced Video Coding (AVC) hardware acceleration • VC1 hardware acceleration based on SMPTE 421M and its derivative standards • ChromotionHD 2.0 Programmable Video Engine • DX10.1 Unified Shader Architecture - Shader Model 4.1
Multiple Displays	<ul style="list-style-type: none"> • Supports 4 displays <ul style="list-style-type: none"> - VGA + LVDS + Bottom DVI-I + Top DVI-I or - VGA + LVDS + Bottom DVI-I + HDMI
Audio	<ul style="list-style-type: none"> • Realtek ALC262 2-channel High Definition Audio • High performance DACs with 100dB SNR • ADCs with 90dB SNR • Two stereo DACs support 24-bit PCM format for stereo audio playback • Three stereo ADCs support 20-bit PCM format for multiple input streaming • S/PDIF input/output interface
LAN	<ul style="list-style-type: none"> • Realtek RTL8111DL PCI Express Gigabit Ethernet controller • Integrated 10/100/1000 transceiver • Supports Full Duplex flow control (IEEE 802.3x) • Fully compliant with IEEE 802.3, IEEE 802.3u, IEEE 802.3ab • Supports power down / link down power saving
Serial ATA	<ul style="list-style-type: none"> • Supports 3 SATA (Serial ATA) interfaces which are compliant with SATA 1.0 specification • SATA speed up to 3Gb/s
Rear Panel I/O Ports	<ul style="list-style-type: none"> • 1 DC-in 12V jack • 2 DVI-I ports (1 shared with HDMI port) • 1 DB-15 VGA port • 1 HDMI port • 1 RJ45 LAN port • 6 USB 2.0/1.1 ports • Mic-in, line-in and line-out

I/O Connectors	<ul style="list-style-type: none"> • 1 CompactFlash socket • 2 connectors for 4 additional external USB 2.0/1.1 ports • 2 connectors for 2 external serial ports • 1 connector for PS/2 keyboard/mouse ports • 1 LVDS LCD panel connector • 1 LCD/inverter power connector • 1 DIO connector • 1 DIO power connector • 1 front audio connector for line-out and mic-in jacks • 1 CD-in internal audio connector • 1 S/PDIF connector • 3 Serial ATA connectors • 1 44-pin IDE connector • 1 4-pin power connector • 1 front panel connector • 1 chassis intrusion connector • 2 fan connectors
BIOS	<ul style="list-style-type: none"> • AMI BIOS • SPI BIOS
Energy Efficient Design	<ul style="list-style-type: none"> • ACPI specification and OS Directed Power Management • System states: S0, S3, S4 and S5 • Wake-On-Events include: <ul style="list-style-type: none"> - Wake-On-PS/2 KB/Mouse, Wake-On-USB KB/Mouse - Wake-On-LAN - RTC timer to power-on the system • System power management supported • Soft Power supported - ACPI v1.0a specification • AC power failure recovery
Damage Free Intelligence	<ul style="list-style-type: none"> • Monitors CPU/system temperature and overheat alarm • Monitors CPU(V)/3.3V/5V/12V/VBAT(V) voltages and failure alarm • Monitors system fan speed and failure alarm • Read back capability that displays temperature, voltage and fan speed • Watchdog timer function
Temperature	<ul style="list-style-type: none"> • 0°C to 60°C
Humidity	<ul style="list-style-type: none"> • 10% to 90%
PCB	<ul style="list-style-type: none"> • Mini-ITX form factor • 17cm (6.7") x 17cm (6.7")

Features

Watchdog Timer

The Watchdog Timer function allows your application to regularly “clear” the system at the set time interval. If the system hangs or fails to function, it will reset at the set time interval so that your system will continue to operate.

CompactFlash

The system board is equipped with the CompactFlash™ socket for inserting a CompactFlash™ card. CompactFlash™ card is a small removable mass storage device designed with flash technology - a non-volatile storage solution that does not require a battery to retain data indefinitely. The CompactFlash™ technology is widely used in products such as portable and desktop computers, digital cameras, handheld data collection scanners, PDAs, Pocket PCs, handy terminals and personal communicators.

DDR2

DDR2 is a higher performance DDR technology whose data transfer rate delivers bandwidth of 4.3 GB per second and beyond. That is twice the speed of the conventional DDR without increasing its power consumption. DDR2 SDRAM modules work at 1.8V supply compared to 2.6V memory voltage for DDR modules. DDR2 also incorporates new innovations such as the On-Die Termination (ODT) as well as larger 4-bit pre-fetch against DDR which fetches 2 bits per clock cycle.

Integrated Graphics

The integrated Intel Gen3.5 graphics engine delivers an excellent video and 3D graphics for large display applications. Graphics interfaces such as VGA, DVI and LVDS support multiple graphics display options.

S3 Graphics

The S3 Graphics Chrome 435 ULP provides hardware acceleration for all leading video standards including H.264, VC-1, MPEG-2, WMV-HD, and AVS, for a stunning HD movie experience. It enables complete multimedia solution of real-time rendering capabilities for life-like visualization of 3D graphics and images for an enhanced game experience and 3D application look-and-feel, along with full 1080p dual-stream (PiP) playback. Graphics interfaces such as DVI and HDMI support multiple graphics display options.

DVI

DVI (Digital Visual Interface) is a form of video interface technology made to maximize the quality of flat panel LCD monitors and modern video graphics cards. Data is transmitted using the TMDS (Transition Minimized Differential Signaling) protocol, providing a digital signal from the PC's graphics subsystem to the display.

LVDS

The Low-Voltage Differential Signaling (LVDS) interface allows the Intel Graphics Media Adapter to communicate directly to the flat-panel display. The LVDS interface supports pixel color depths of 18 bits.

HDMI

HDMI (High-Definition Multimedia Interface) is a compact audio/video connector interface for transmitting uncompressed digital streams. It delivers multi-channel audio and uncompressed digital video signals for full HD 1080p visuals through a single cable. Connect a LCD monitor or digital TV that has the HDMI port.

PCI Express

PCI Express is a high bandwidth I/O infrastructure that possesses the ability to scale speeds by forming multiple lanes. The x1 PCI Express lane supports transfer rate of 2.5 Gigabytes (250MBbps) per second which is nearly 4 times faster than the traditional PCI.

Audio

The Realtek ALC262 audio codec provides 2-channel High Definition audio output.

S/PDIF

S/PDIF is a standard audio file transfer format that transfers digital audio signals to a device without having to be converted first to an analog format. This prevents the quality of the audio signal from degrading whenever it is converted to analog. S/PDIF is usually found on digital audio equipment such as a DAT machine or audio processing device. The S/PDIF connector on the system board sends surround sound and 3D audio signal outputs to amplifiers and speakers and to digital recording devices like CD recorders.

Serial ATA

Serial ATA is a storage interface that is compliant with SATA 1.0a specification. With speed of up to 3GB/s, it improves hard drive performance faster than the standard parallel ATA whose data transfer rate is 100MB/s.

Gigabit LAN

The Realtek RTL8111DL PCI Express Gigabit controllers support up to 1Gbps data transmission.

USB

The system board supports USB 2.0 and USB 1.1 ports. USB 1.1 supports 12Mb/second bandwidth while USB 2.0 supports 480Mb/second bandwidth providing a marked improvement in device transfer speeds between your computer and a wide range of simultaneously accessible external Plug and Play peripherals.

Wake-On-LAN

This feature allows the network to remotely wake up a Soft Power Down (Soft-Off) PC. It is supported via the onboard LAN port or via a PCI LAN card that uses the PCI PME (Power Management Event) signal. However, if your system is in the Suspend mode, you can power-on the system only through an IRQ or DMA interrupt.

**Important:**

The 5V_standby power source of your power supply must support $\geq 720\text{mA}$.

Wake-On-PS/2

This function allows you to use the PS/2 keyboard or PS/2 mouse to power-on the system.

**Important:**

The 5V_standby power source of your power supply must support $\geq 720\text{mA}$.

Wake-On-USB

This function allows you to use a USB keyboard or USB mouse to wake up a system from the S3 (STR - Suspend To RAM) state.

**Important:**

If you are using the Wake-On-USB Keyboard/Mouse function for 2 USB ports, the 5V_standby power source of your power supply must support $\geq 1.5\text{A}$. For 3 or more USB ports, the 5V_standby power source of your power supply must support $\geq 2\text{A}$.

RTC Timer

The RTC installed on the system board allows your system to automatically power-on on the set date and time.

ACPI STR

The system board is designed to meet the ACPI (Advanced Configuration and Power Interface) specification. ACPI has energy saving features that enables PCs to implement Power Management and Plug-and-Play with operating systems that support OS Direct Power Management. ACPI when enabled in the Power Management Setup will allow you to use the Suspend to RAM function.

With the Suspend to RAM function enabled, you can power-off the system at once by pressing the power button or selecting "Standby" when you shut down Windows® without having to go through the sometimes tiresome process of closing files, applications and operating system. This is because the system is capable of storing all programs and data files during the entire operating session into RAM (Random Access Memory) when it powers-off. The operating session will resume exactly where you left off the next time you power-on the system.



Important:

The 5V_standby power source of your power supply must support $\geq 720\text{mA}$.

Power Failure Recovery

When power returns after an AC power failure, you may choose to either power-on the system manually or let the system power-on automatically.

Chapter 2 - Hardware Installation

System Board Layout

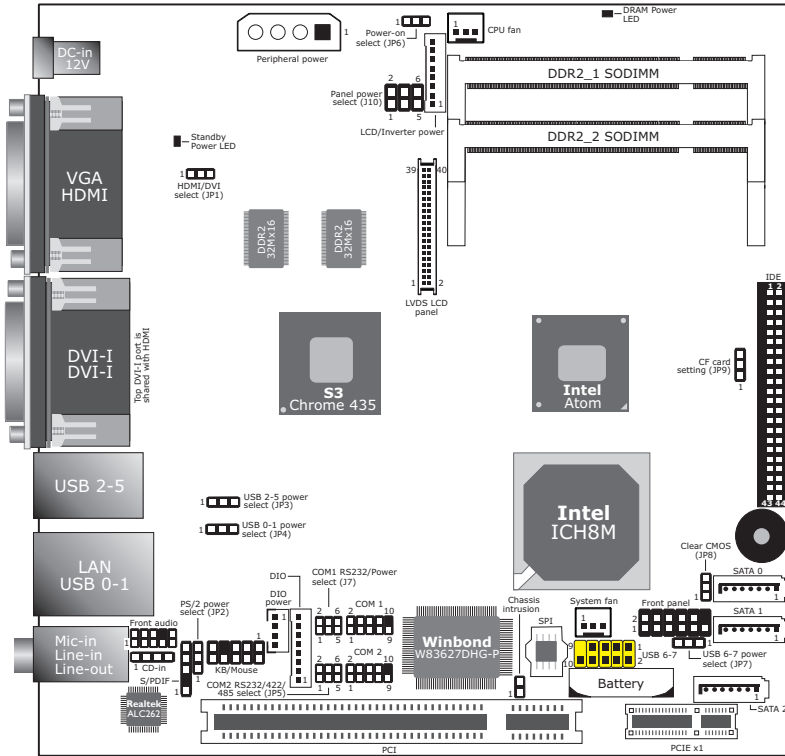

**Important:**

Electrostatic discharge (ESD) can damage your system board, processor, disk drives, add-in boards, and other components. Perform the upgrade instruction procedures described at an ESD workstation only. If such a station is not available, you can provide some ESD protection by wearing an antistatic wrist strap and attaching it to a metal part of the system chassis. If a wrist strap is unavailable, establish and maintain contact with the system chassis throughout any procedures requiring ESD protection.

System Memory

**Important:**

When the Standby Power LED lit red, it indicates that there is power on the system board. Power-off the PC then unplug the power cord prior to installing any devices. Failure to do so will cause severe damage to the motherboard and components.

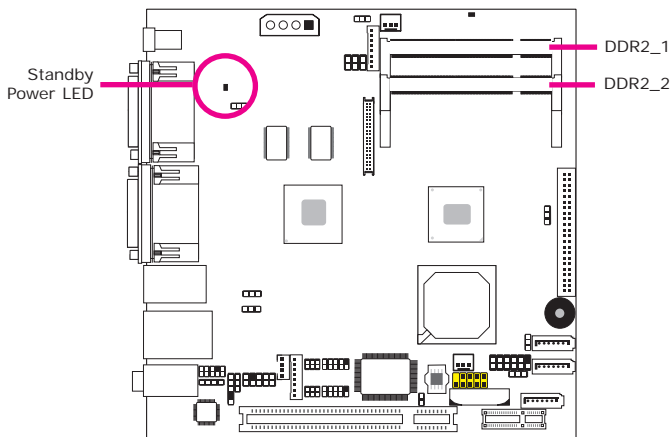

The system board supports two DDR2 SODIMM sockets.

**Note:**

The system board supports maximum of 2GB system memory however you can install maximum of 1GB only per SODIMM socket.

Installing the DIM Module

**Note:**

The system board used in the following illustrations may not resemble the actual one. These illustrations are for reference only.

1. Make sure the PC and all other peripheral devices connected to it has been powered down.
2. Disconnect all power cords and cables.
3. Locate the SODIMM socket on the system board.
4. Note the key on the socket. The key ensures the module can be plugged into the socket in only one direction.

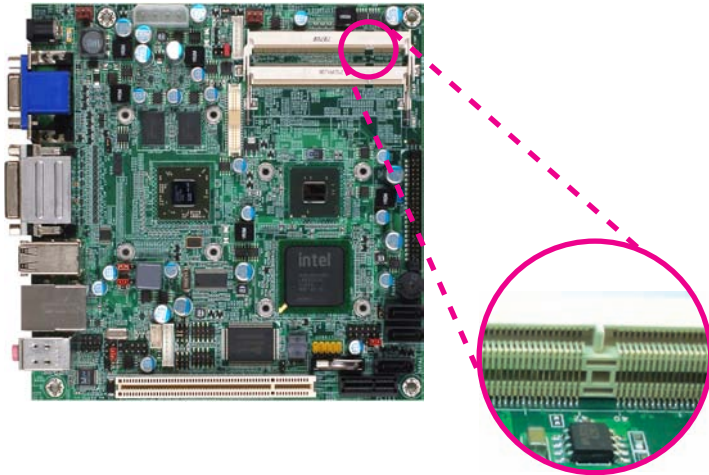

5. Grasping the module by its edges, align the module into the socket at an approximately 30 degrees angle. Apply firm even pressure to each end of the module until it slips down into the socket. The contact fingers on the edge of the module will almost completely disappear inside the socket.



6. Push down the module until the clips at each end of the socket lock into position. You will hear a distinctive “click”, indicating the module is correctly locked into position.



Jumper Settings

Clear CMOS Data

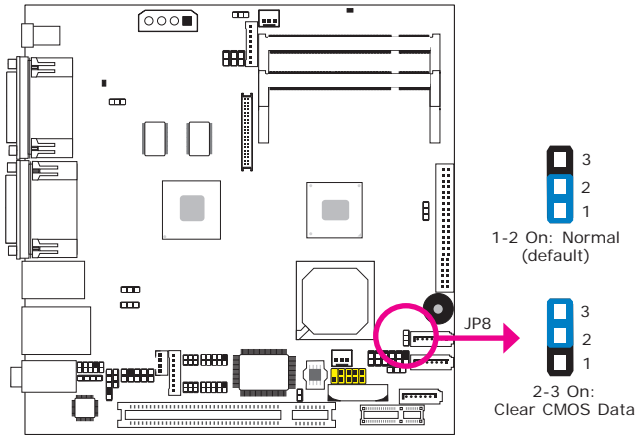

If you encounter the following,

- a) CMOS data becomes corrupted.
- b) You forgot the supervisor or user password.

you can reconfigure the system with the default values stored in the ROM BIOS.

To load the default values stored in the ROM BIOS, please follow the steps below.

1. Power-off the system and unplug the power cord.
2. Set JP8 pins 2 and 3 to On. Wait for a few seconds and set JP8 back to its default setting, pins 1 and 2 On.
3. Now plug the power cord and power-on the system.

PS/2 Power Select

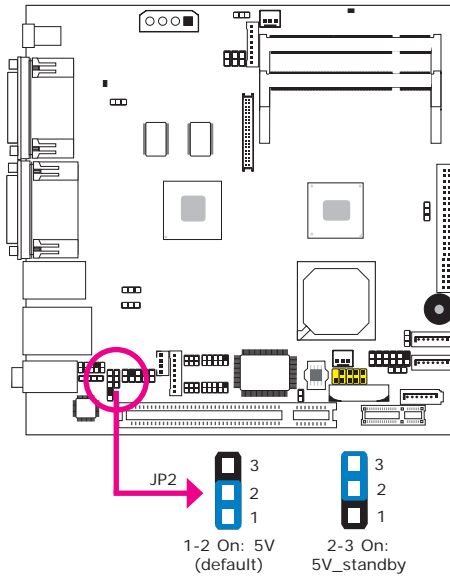

JP2 is used to select the power of the PS/2 keyboard/mouse port. Selecting 5V_standby will allow you to use the PS/2 keyboard or PS/2 mouse to wake up the system.

USB Power Select

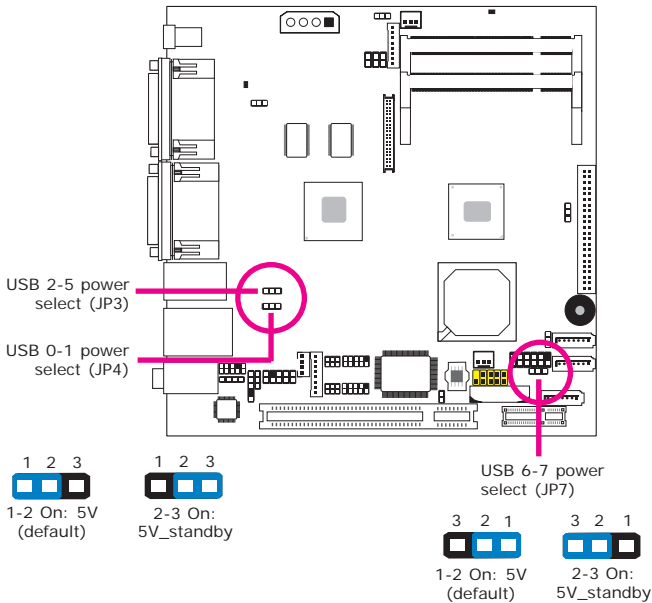

JP3 (for USB 2-5), JP4 (for USB 0-1) and JP7 (for USB 6-7) are used to select the power of the USB ports. Selecting 5V_standby will allow you to use a USB device to wake the system.

BIOS Setting

"USB Device Wakeup From S3" in the Advanced menu ("ACPI Configuration" sub-menu) of the BIOS must be set to Enabled. Refer to chapter 3 for more information.

**Important:**

If you are using the Wake-On-USB Keyboard/Mouse function for 2 USB ports, the 5V_standby power source of your power supply must support $\geq 1.5A$. For 3 or more USB ports, the 5V_standby power source of your power supply must support $\geq 2A$.

Panel Power Select

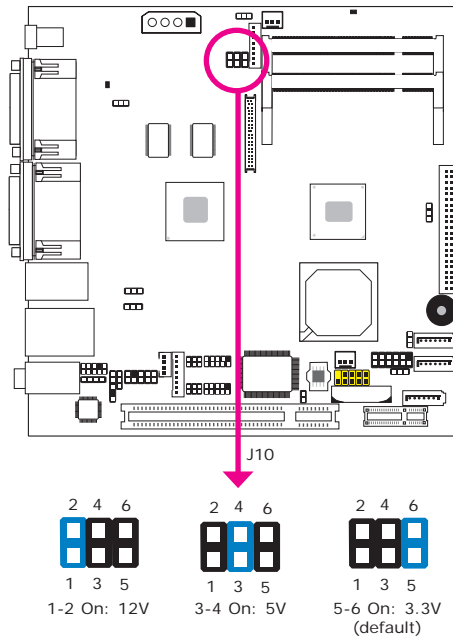

J10 is used to select the power supplied to the LCD panel.

**Important:**

Before powering-on the system, make sure J10's setting matches the LCD panel's specification. Selecting the incorrect voltage will seriously damage the LCD panel.

CompactFlash Card Setting

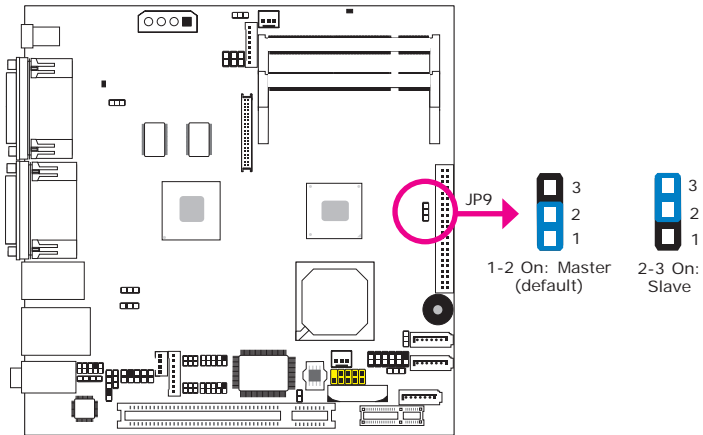

JP9 is used to set the CompactFlash card to Master or Slave mode.

**Note:**

We do not recommend using IDE devices and CF card at the same time.

COM 2 RS232/RS422/RS485 Select

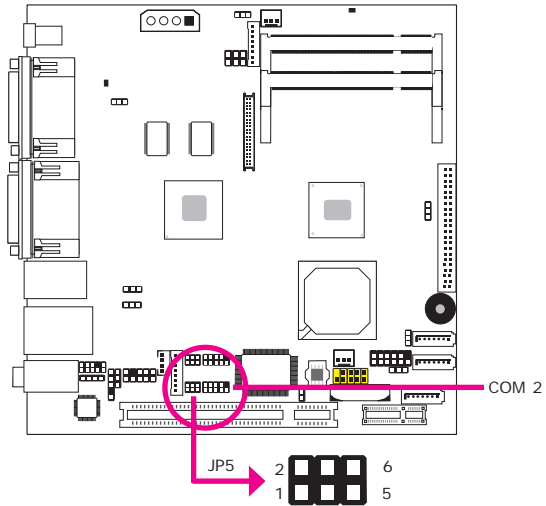

JP5 is used to configure COM 2 to RS232, RS422 (Half Duplex) or RS485.

The pin function of COM 2 will vary according to the jumper's setting.

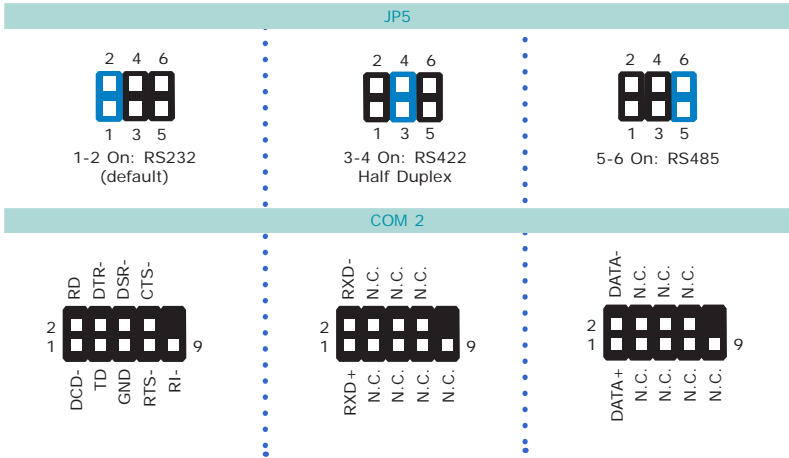

COM 1 RS232/Power Select

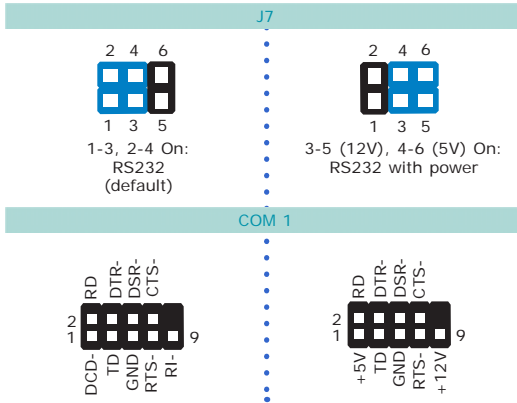
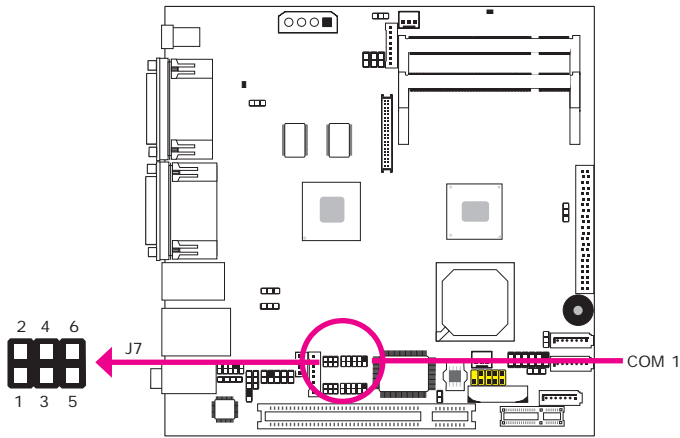

HDMI/DVI Select

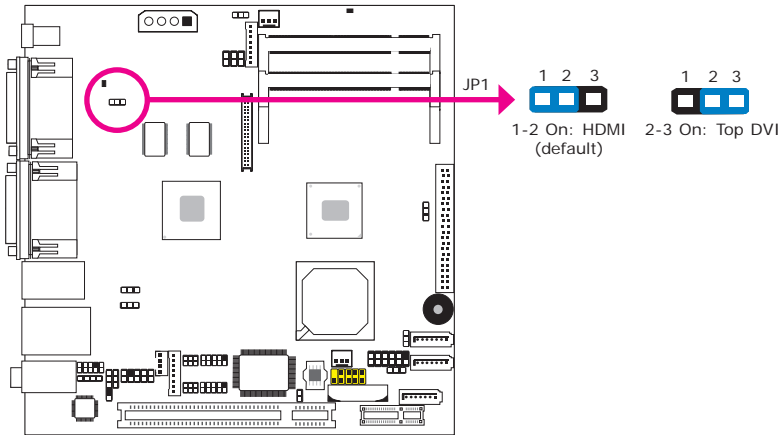

The S3 Graphics Chrome® 435 ULP GPU supports 2 DVI-I and 1 HDMI display interfaces; however it does not support using the 3 display ports at the same time. For dual display, use the bottom DVI-I with either the top DVI-I or HDMI. Make sure to set JP1 accordingly.

Display options supported by S3:

Bottom DVI-I + Top DVI-I
or
Bottom DVI-I + HDMI

To change the jumper's setting:

1. Power-off the system and then unplug the power cord.
2. Change the jumper's setting.
3. Now plug the power cord and then power-on the system.

Power-on Select

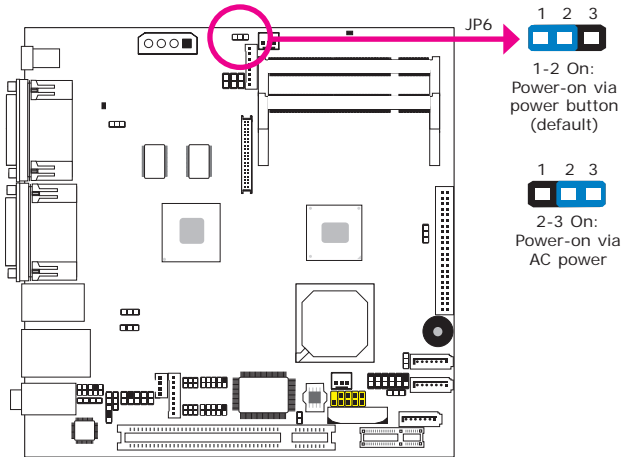

JP6 is used to select the method of powering on the system. If you want the system to power-on whenever AC power comes in, set JP6 pins 2 and 3 to On. If you want to use the power button, set pins 1 and 2 to On.

When using the JP6 "Power On" feature to power the system back on after a power failure occurs, the system may not power on if the power lost is resumed within 5 seconds (power flicker).

**Note:**

In order to ensure that power is resumed after a power failure that recovers within a 5 second period, JP6 must be set to pins 2-3 and the "PWRON After PWR-Fail" in CMOS is set to "On".

Rear Panel I/O Ports

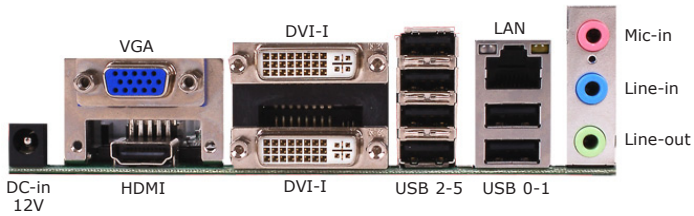

The rear panel I/O ports consist of the following:

- DC-in 12V jack
- VGA port
- HDMI port
- 2 DVI-I ports
- 6 USB ports
- LAN port
- Mic-in jack
- Line-in jack
- Line-out jack

DC-in 12V

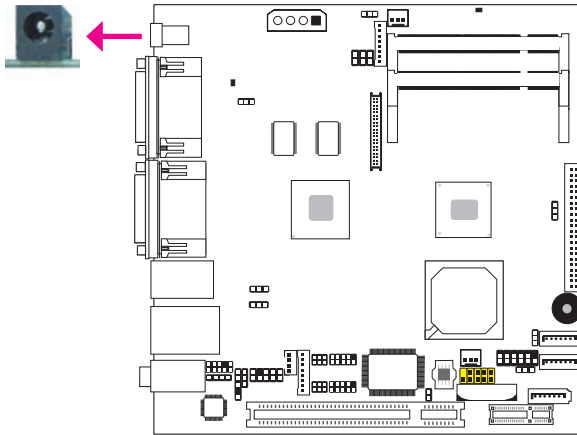

This jack provides maximum of 60W power and is considered a low power solution. Connect a DC power cord to this jack. Use a power adapter with 12V DC output voltage. Using a voltage higher than the recommended one may fail to boot the system or cause damage to the system board.

**Important:**

Every power supply has its minimum load of power. If you use a greater than 150W power supply, the power consumed by the system board may not attain its minimum load causing instability to the entire system.

VGA Port

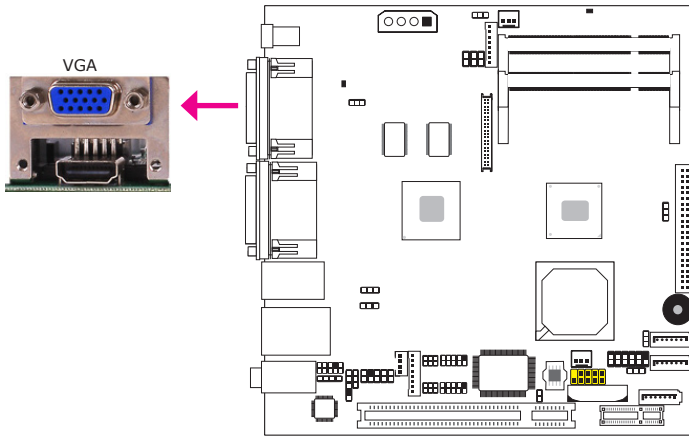

The VGA port is used for connecting a VGA monitor. Connect the monitor's 15-pin D-shell cable connector to the VGA port. After you plug the monitor's cable connector into the VGA port, gently tighten the cable screws to hold the connector in place.

BIOS Setting

Configure the onboard VGA in the Chipset menu ("North Bridge Configuration" submenu) of the BIOS. Refer to chapter 3 for more information.

Driver Installation

Install the graphics driver. Refer to chapter 4 for more information.

HDMI Port

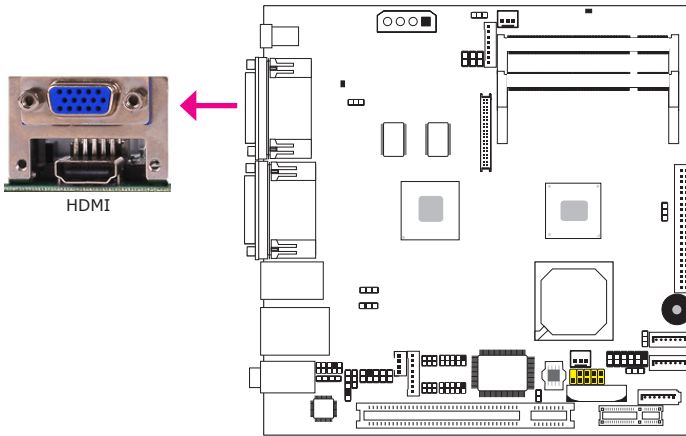

The HDMI port which carries both digital audio and video signals is used to connect a LCD monitor or digital TV that has the HDMI port.

The S3 Graphics Chrome® 435 ULP GPU supports 2 DVI-I and 1 HDMI display interfaces; however it does not support using the 3 display ports at the same time.

For dual display, use the HDMI port with the bottom DVI-I port.

Make sure to set JP1 accordingly.

DVI-I Ports

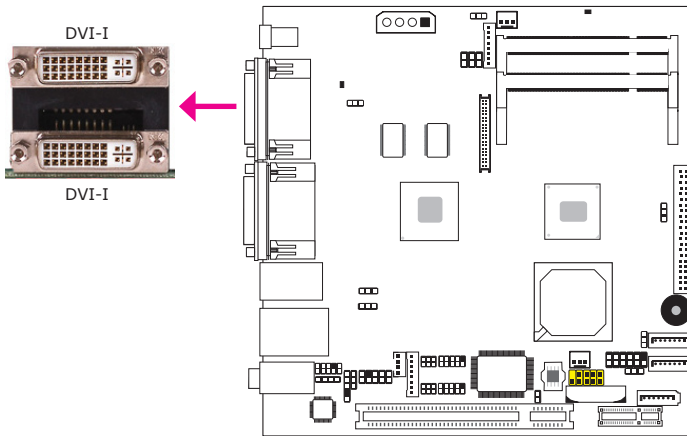

The DVI-I port is used to connect an LCD monitor. Connect the display device's cable connector to the DVI-I port. After you plug the cable connector into the port, gently tighten the cable screws to hold the connector in place.

The S3 Graphics Chrome® 435 ULP GPU supports 2 DVI-I and 1 HDMI display interfaces; however it does not support using the 3 display ports at the same time.

For dual display, use the bottom DVI-I with either the top DVI-I or HDMI.

Make sure to set JP1 accordingly.

USB Ports

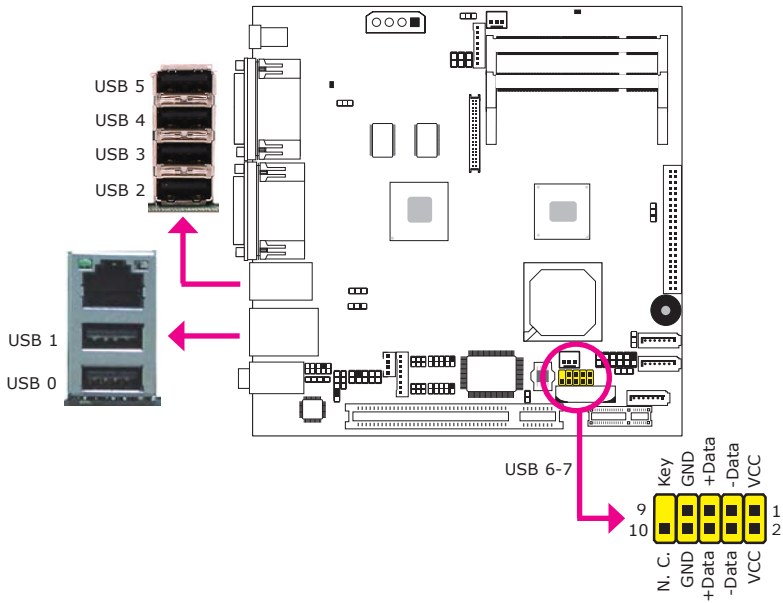

USB allows data exchange between your computer and a wide range of simultaneously accessible external Plug and Play peripherals.

The system board is equipped with 6 onboard USB 2.0/1.1 ports. The 10-pin connector allows you to connect 2 additional USB 2.0/1.1 ports. The USB ports may be mounted on a card-edge bracket. Install the card-edge bracket to an available slot at the rear of the system chassis then insert the USB port cables to the connector.

BIOS Setting

Configure the onboard USB in the Chipset menu ("South Bridge Configuration" submenu) of the BIOS. Refer to chapter 3 for more information.

Driver Installation

You may need to install the proper drivers in your operating system to use the USB device. Refer to your operating system's manual or documentation for more information.

Wake-On-USB Keyboard/Mouse

The Wake-On-USB Keyboard/Mouse function allows you to use a USB keyboard or USB mouse to wake up a system from the S3 (STR - Suspend To RAM) state. To use this function:

- **Jumper Setting**

JP3, JP4 and/or JP7 must be set to "2-3 On: 5V_standby". Refer to "USB Power Select" in this chapter for more information.

- **BIOS Setting**

"USB Device Wakeup From S3" in the Advanced menu ("ACPI Configuration" submenu) of the BIOS must be set to Enabled. Refer to chapter 3 for more information.



Important:

If you are using the Wake-On-USB Keyboard/Mouse function for 2 USB ports, the 5V_standby power source of your power supply must support $\geq 1.5A$. For 3 or more USB ports, the 5V_standby power source of your power supply must support $\geq 2A$.

RJ45 LAN Port

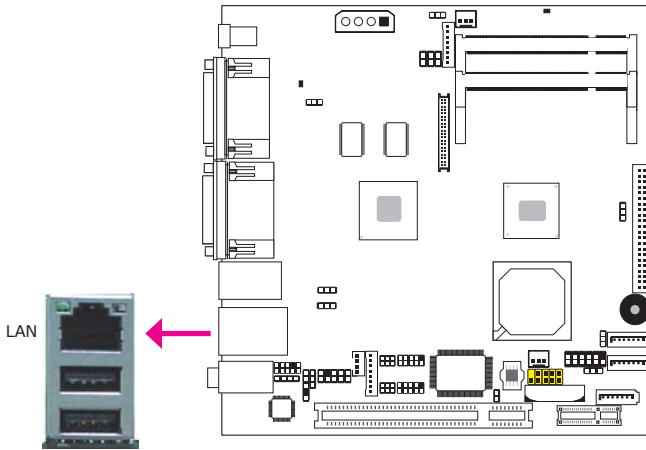

The LAN port allows the system board to connect to a local area network by means of a network hub.

BIOS Setting

Configure the onboard LAN ports in the Chipset menu ("South Bridge Configuration" submenu) of the BIOS. Refer to chapter 3 for more information.

Driver Installation

Install the LAN drivers. Refer to chapter 4 for more information.

Audio

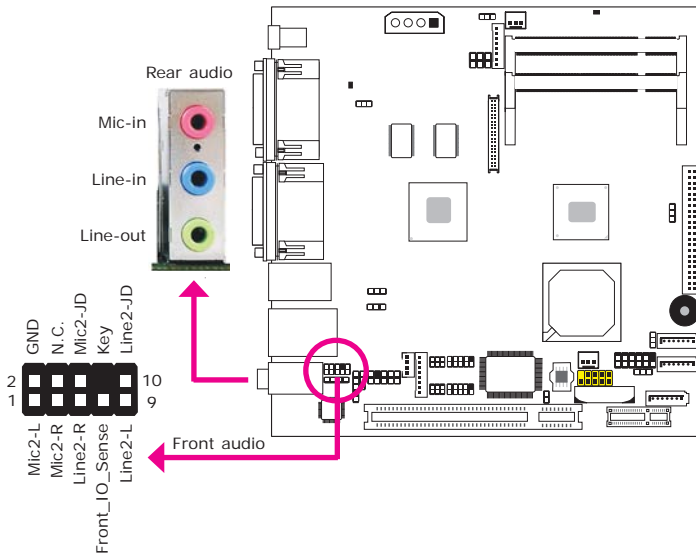

Rear Audio

The system board is equipped with 3 audio jacks. A jack is a one-hole connecting interface for inserting a plug.

- **Mic-in Jack (Pink)**
This jack is used to connect an external microphone.
- **Line-in Jack (Light Blue)**
This jack is used to connect any audio devices such as Hi-fi set, CD player, tape player, AM/FM radio tuner, synthesizer, etc.
- **Line-out Jack (Lime)**
This jack is used to connect a headphone or external speakers.

Front Audio

The front audio connector allows you to connect to the second line-out and mic-in jacks that are at the front panel of your system.

BIOS Setting

Configure the onboard audio in the Chipset menu ("South Bridge Configuration" submenu) of the BIOS. Refer to chapter 3 for more information.

Driver Installation

Install the audio driver. Refer to chapter 4 for more information.

I/O Connectors

KB/Mouse Connector

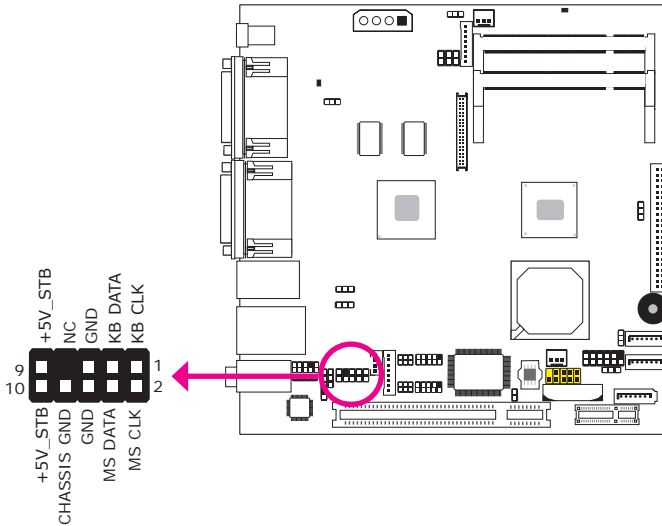

The KB/Mouse connector is used to connect PS/2 keyboard and PS/2 mouse by means of a PS/2 cable.

Connecting the PS/2 Cable

The system board package comes with a PS/2 cable. Connect one end of the cable to the KB/Mouse connector. The other ends are used to connect a PS/2 keyboard and a PS/2 mouse.

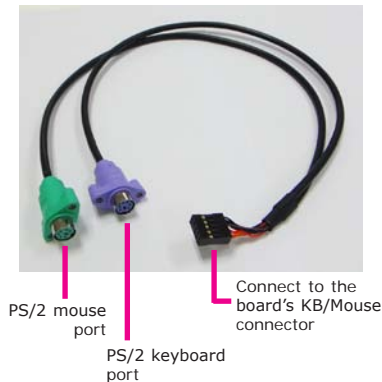

Wake-On-PS/2 Keyboard/Mouse

The Wake-On-PS/2 Keyboard/Mouse function allows you to use the PS/2 keyboard or PS/2 mouse to power-on the system. To use this function:

- **Jumper Setting**

JP2 must be set to "2-3 On: 5V_standby". Refer to "PS/2 Power Select" in this chapter for more information.



Important:

The 5V_standby power source of your power supply must support $\geq 720\text{mA}$.

CD-in Internal Audio Connector

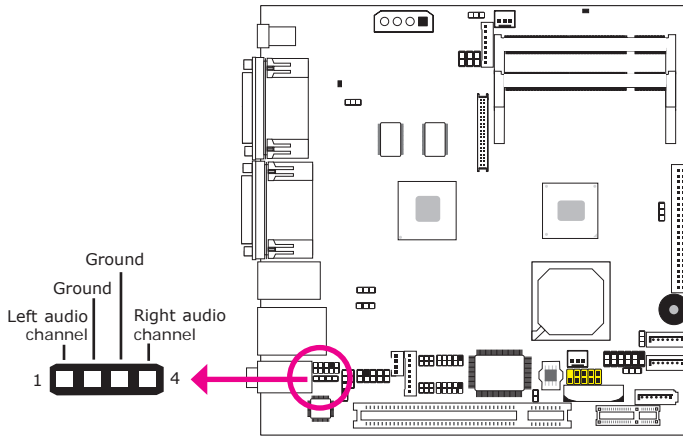

The CD-in connector is used to receive audio from a CD-ROM drive, TV tuner or MPEG card.

S/PDIF Connector

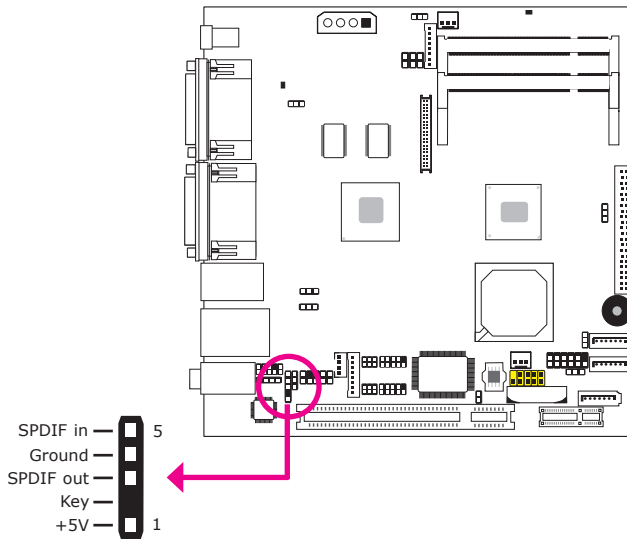

The S/PDIF connector is used to connect an external S/PDIF port. Your S/PDIF port may be mounted on a card-edge bracket. Install the card-edge bracket to an available slot at the rear of the system chassis then connect the audio cable to the S/PDIF connector. Make sure pin 1 of the audio cable is aligned with pin 1 of the S/PDIF connector.

LVDS LCD Panel Connector LCD/Inverter Power Connector

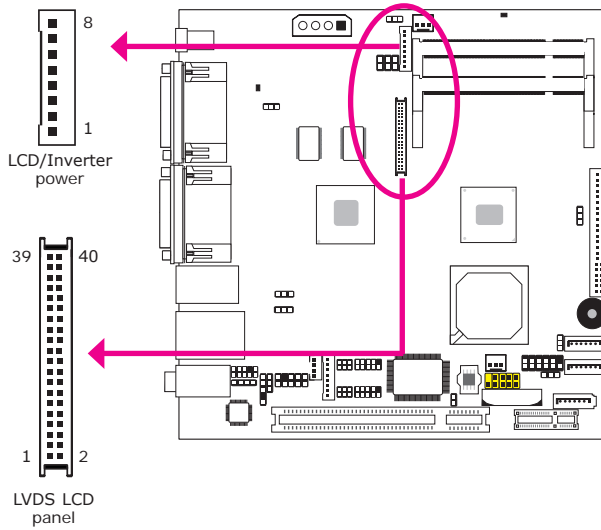

The system board allows you to connect a LCD Display Panel by means of the LVDS LCD panel connector and the LCD/Inverter power connector. These connectors transmit video signals and power from the system board to the LCD Display Panel.

Refer to the next page for the pin functions of these connectors.

BIOS Setting

Configure the LCD panel in the Chipset menu ("North Bridge Configuration" sub-menu) of the BIOS. Refer to chapter 3 for more information.

LVDS LCD Panel Connector

Pins	Function	Pins	Function
1	GND	2	GND
3	N. C.	4	N. C.
5	N. C.	6	N. C.
7	GND	8	GND
9	LVDS_Out2+	10	N. C.
11	LVDS_Out2-	12	N. C.
13	GND	14	GND
15	LVDS_Out1+	16	N. C.
17	LVDS_Out1-	18	N. C.
19	GND	20	GND
21	LVDS_Out0+	22	N. C.
23	LVDS_Out0-	24	N. C.
25	GND	26	GND
27	LVDS_CLK1+	28	N. C.
29	LVDS_CLK1-	30	N. C.
31	GND	32	GND
33	LVDS_DDCCLK	34	N. C.
35	LVDS_DDCDAA	36	N. C.
37	Panel Power	38	Panel Power
39	Panel Power	40	Panel Power

LCD/Inverter Power Connector

Pins	Function
1	GND
2	GND
3	Panel Inverter Brightness Voltage Control
4	Panel Power
5	+3.3V
6	Panel Backlight On/Off Control
7	+12V
8	+12V

Digital I/O Connector

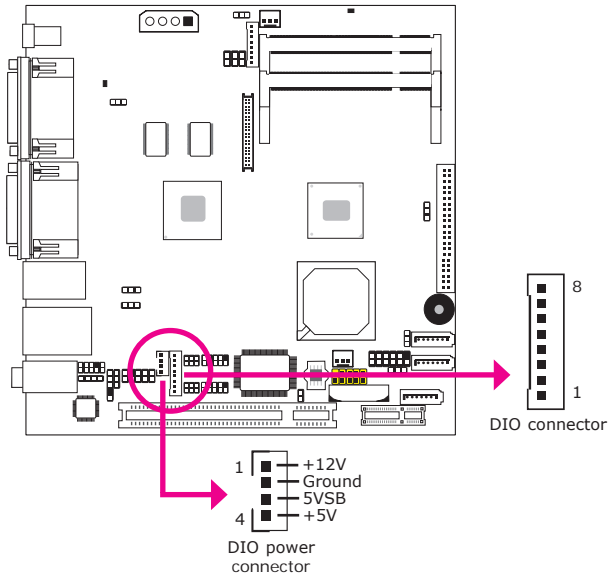

The Digital I/O connector provides powering-on function to an external device that is connected to this connector.

Digital I/O Connector

Pins	Function
1	DIO0
2	DIO1
3	DIO2
4	DIO3
5	DIO4
6	DIO5
7	DIO6
8	DIO7

SATA (Serial ATA) Connectors

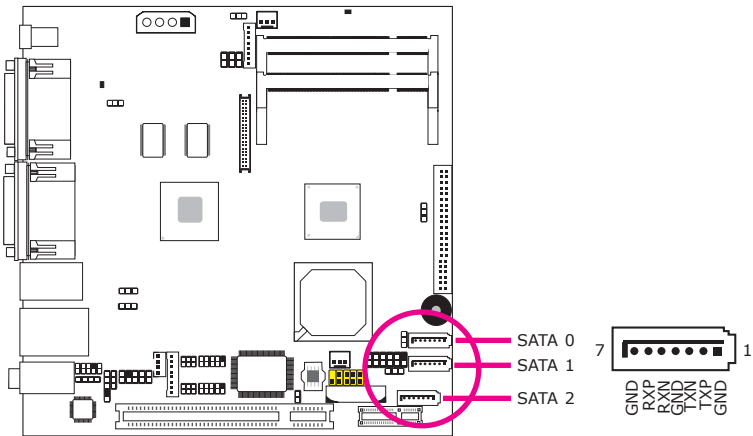

The Serial ATA connectors are used to connect Serial ATA devices. Connect one end of the Serial ATA cable to a SATA connector and the other end to your Serial ATA device.

BIOS Setting

Configure the Serial ATA drives in the Advanced menu ("IDE Configuration" sub-menu) of the BIOS. Refer to chapter 3 for more information.

IDE Connector

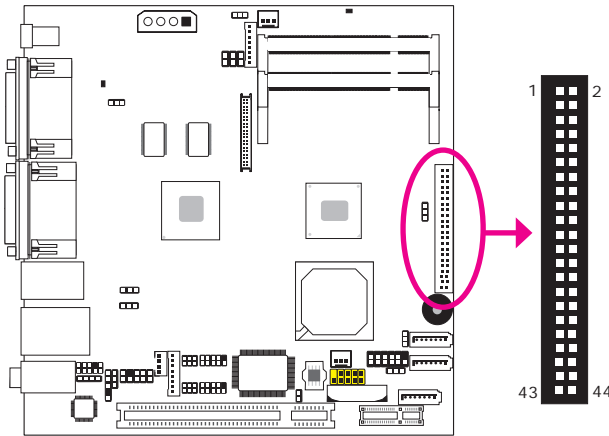
**Important:**

We do not recommend using IDE devices and CF card at the same time.

The IDE connector is used to connect hard drives. The connector on the IDE cable can be inserted into this connector only if pin 1 of the cable is aligned with pin 1 of this connector.

The IDE connector supports 2 devices, a Master and a Slave. Use an IDE ribbon cable to connect the drives to the system board. An IDE ribbon cable has 3 connectors on them, one that plugs into the IDE connector on the system board and the other 2 connect to IDE devices. The connector at the end of the cable is for the Master drive and the connector in the middle of the cable is for the Slave drive.

**Note:**

Refer to your disk drive user's manual for information about selecting proper drive switch settings.

Adding a Second IDE Disk Drive

When using two IDE drives, one must be set as the master and the other as the slave. Follow the instructions provided by the drive manufacturer for setting the jumpers and/or switches on the drives.

The system board supports Enhanced IDE or ATA-2 and ATA/33 hard drives. We recommend that you use hard drives from the same manufacturer. In a few cases, drives from two different manufacturers will not function properly when used together. The problem lies in the hard drives, not the system board.

**Important:**

If you encountered problems while using an ATAPI CD-ROM drive that is set in Master mode, please set the CD-ROM drive to Slave mode. Some ATAPI CD-ROMs may not be recognized and cannot be used if incorrectly set in Master mode.

BIOS Setting

Configure the onboard IDE in the Advanced menu ("IDE Configuration" submenu) of the BIOS. Refer to chapter 3 for more information.

Cooling Fan Connectors

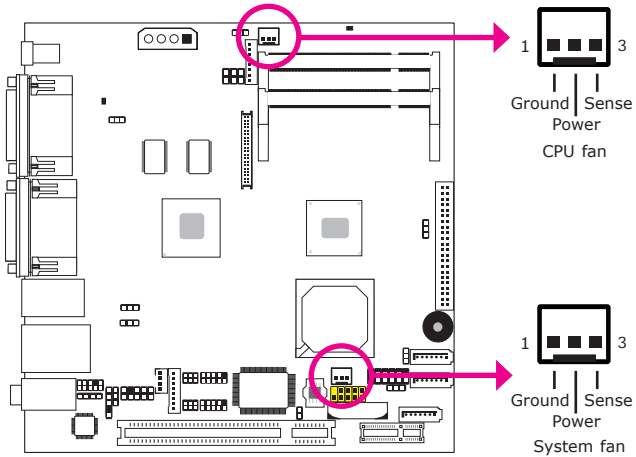

The fan connectors are used to connect cooling fans. The cooling fans will provide adequate airflow throughout the chassis to prevent overheating the CPU and system board components.

BIOS Setting

The Advanced menu ("Hardware Health Configuration" submenu) of the BIOS will display the current speed of the cooling fan. Refer to chapter 3 for more information.

Chassis Intrusion Connector

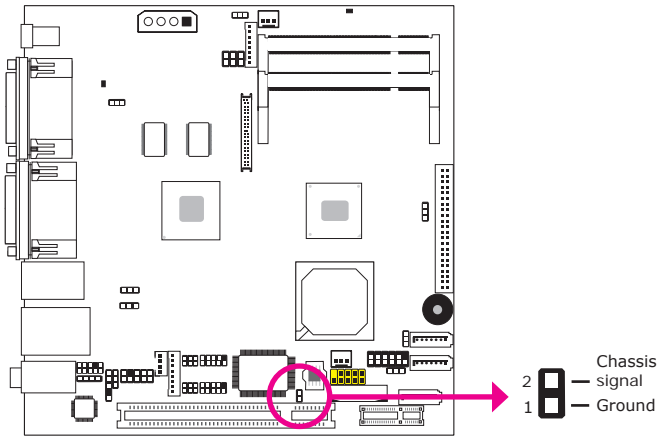

The board supports the chassis intrusion detection function. Connect the chassis intrusion sensor cable from the chassis to this connector. When the system's power is on and a chassis intrusion occurred, an alarm will sound. When the system's power is off and a chassis intrusion occurred, the alarm will sound only when the system restarts.

Hardware Monitor for Windows

Install the "Hardware Monitor for Windows" utility. By default, the chassis intrusion detection function is disabled. When enabled, a warning message will appear when the chassis is open. The utility can also be configured so that a beeping alarm will sound when the chassis is open. Refer to the "Hardware Monitor for Windows" section in chapter 4 for more information.

Peripheral Power Connector

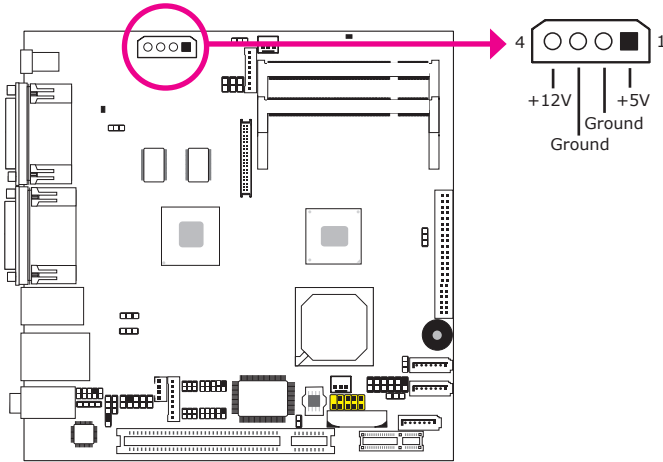

The peripheral power connector supplies power to the SATA drive and IDE hard disk drive. Connect one end of the provided power cable to the peripheral power connector and the other ends to your storage devices.

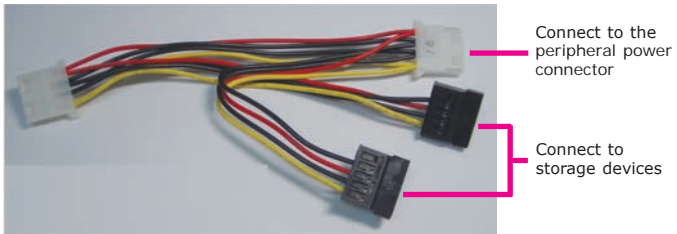

LEDs

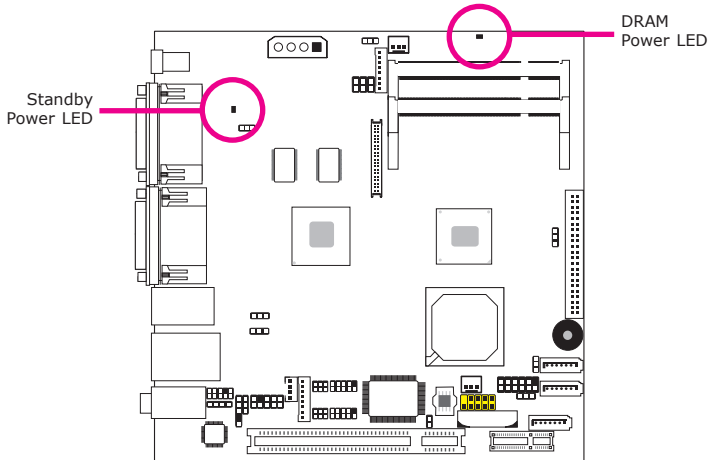

DRAM Power LED

This LED will light when the system's power is on.

Standby Power LED

This LED will light when the system is in the standby mode.



Important:

When the DRAM Power LED and/or Standby Power LED lit red, it indicates that power is present on the DIMM sockets and/or PCI slots. Power-off the PC then unplug the power cord prior to installing any memory modules or add-in cards. Failure to do so will cause severe damage to the motherboard and components.

Front Panel Connectors

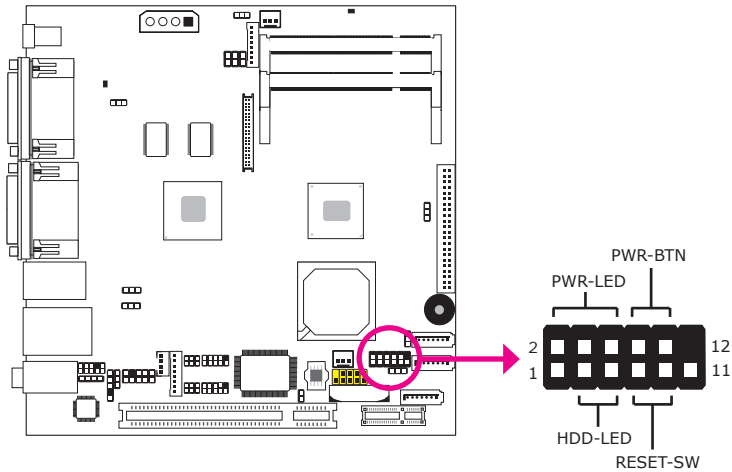

HDD-LED - HDD LED

This LED will light when the hard drive is being accessed.

RESET SW - Reset Switch

This switch allows you to reboot without having to power off the system.

PWR-BTN - Power Switch

This switch is used to power on or off the system.

PWR-LED - Power/Standby LED

When the system's power is on, this LED will light. When the system is in the S1 (POS - Power On Suspend) state, it will blink every second. When the system is in the S3 (STR - Suspend To RAM) state, it will blink every 4 seconds.

	Pin	Pin Assignment		Pin	Pin Assignment
N. C.	1	N. C.	PWR-LED	2	LED Power
				4	LED Power
				6	Signal
HDD-LED	3	HDD Power	PWR-BTN	8	GND
	5	Signal		10	Signal
RESET SW	7	Ground			
	9	RST Signal			
N. C.	11	N. C.	Key	12	Key

Expansion Slots

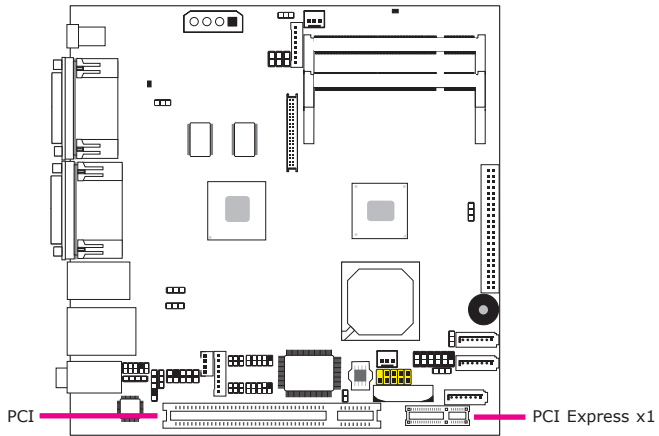

PCI Express x1

Install PCI Express cards such as network cards or other cards that comply to the PCI Express specifications into the PCI Express x1 slot.

PCI Slot

The PCI slot supports expansion cards that comply with PCI specifications. You can install a PCI expansion card or a customized riser card designed for 1, 2 or 3 PCI slots expansion (for low profile PCI card only) into the PCI slot.

Battery

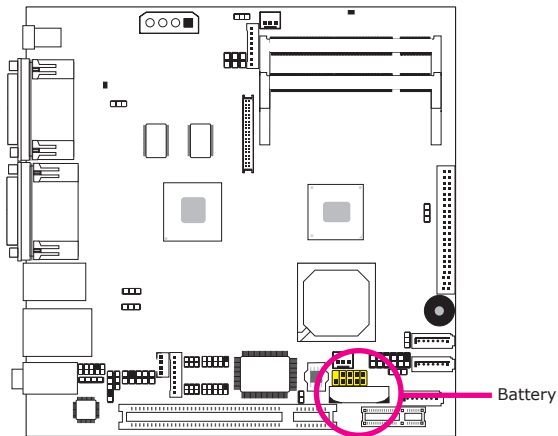

The lithium ion battery powers the real-time clock and CMOS memory. It is an auxiliary source of power when the main power is shut off.

Safety Measures

- Danger of explosion if battery incorrectly replaced.
- Replace only with the same or equivalent type recommend by the manufacturer.
- Dispose of used batteries according to local ordinance.

CompactFlash Socket

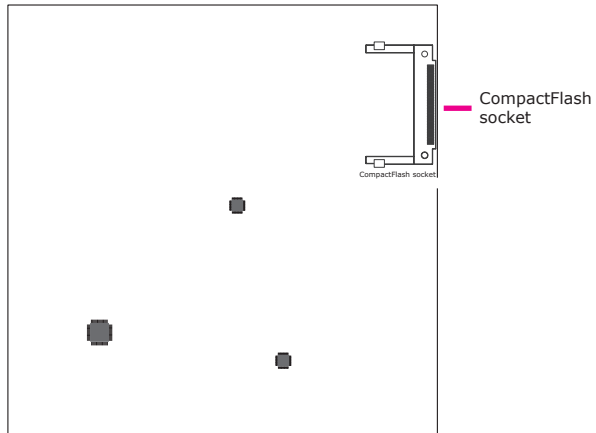

The CompactFlash™ socket is used for inserting a CompactFlash™ card. CompactFlash™ card is a small removable mass storage device designed with flash technology - a non-volatile storage solution that does not require a battery to retain data indefinitely. The CompactFlash™ technology is widely used in products such as portable and desktop computers, digital cameras, handheld data collection scanners, PDAs, Pocket PCs, handy terminals and personal communicators.



Important:

We do not recommend using IDE devices and CF card at the same time.

Chapter 3 - BIOS Setup

Overview

The BIOS is a program that takes care of the basic level of communication between the CPU and peripherals. It contains codes for various advanced features found in this system board. The BIOS allows you to configure the system and save the configuration in a battery-backed CMOS so that the data retains even when the power is off. In general, the information stored in the CMOS RAM of the EEPROM will stay unchanged unless a configuration change has been made such as a hard drive replaced or a device added.

It is possible that the CMOS battery will fail causing CMOS data loss. If this happens, you need to install a new CMOS battery and reconfigure the BIOS settings.



Note:

The BIOS is constantly updated to improve the performance of the system board; therefore the BIOS screens in this chapter may not appear the same as the actual one. These screens are for reference purpose only.

Default Configuration

Most of the configuration settings are either predefined according to the Load Optimal Defaults settings which are stored in the BIOS or are automatically detected and configured without requiring any actions. There are a few settings that you may need to change depending on your system configuration.

Entering the BIOS Setup Utility

The BIOS Setup Utility can only be operated from the keyboard and all commands are keyboard commands. The commands are available at the right side of each setup screen.

The BIOS Setup Utility does not require an operating system to run. After you power up the system, the BIOS message appears on the screen and the memory count begins. After the memory test, the message "Press DEL to run setup" will appear on the screen. If the message disappears before you respond, restart the system or press the "Reset" button. You may also restart the system by pressing the <Ctrl> <Alt> and keys simultaneously.

Legends

Keys	Function
Right and Left arrows	Moves the highlight left or right to select a menu.
Up and Down arrows	Moves the highlight up or down between submenus or fields.
<Esc>	Exits to the BIOS Setup Utility.
+ (plus key)	Scrolls forward through the values or options of the highlighted field.
- (minus key)	Scrolls backward through the values or options of the highlighted field.
Tab	Selects a field.
<F1>	Displays General Help.
<F10>	Saves and exits the Setup program.
<Enter>	Press <Enter> to enter the highlighted submenu.

Scroll Bar

When a scroll bar appears to the right of the setup screen, it indicates that there are more available fields not shown on the screen. Use the up and down arrow keys to scroll through all the available fields.

Submenu

When "»" appears on the left of a particular field, it indicates that a submenu which contains additional options are available for that field. To display the submenu, move the highlight to that field and press <Enter>.

AMI BIOS Setup Utility

Main

The Main menu is the first screen that you will see when you enter the BIOS Setup Utility.

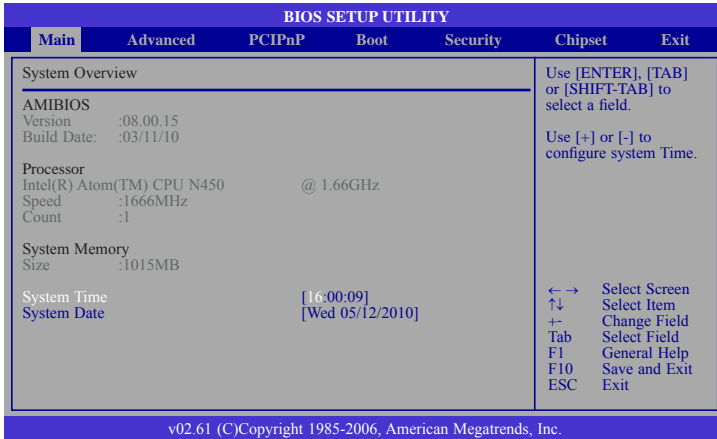

AMI BIOS

Displays the detected BIOS information.

Processor

Displays the detected processor information.

System Memory

Displays the detected system memory information.

System Time

The time format is <hour>, <minute>, <second>. The time is based on the 24-hour military-time clock. For example, 1 p.m. is 13:00:00. Hour displays hours from 00 to 23. Minute displays minutes from 00 to 59. Second displays seconds from 00 to 59.

System Date

The date format is <day>, <month>, <date>, <year>. Day displays a day, from Sunday to Saturday. Month displays the month, from January to December. Date displays the date, from 1 to 31. Year displays the year, from 1980 to 2099.

Advanced

The Advanced menu allows you to configure your system for basic operation. Some entries are defaults required by the system board, while others, if enabled, will improve the performance of your system or let you set some features according to your preference.



Important:

Setting incorrect field values may cause the system to malfunction.

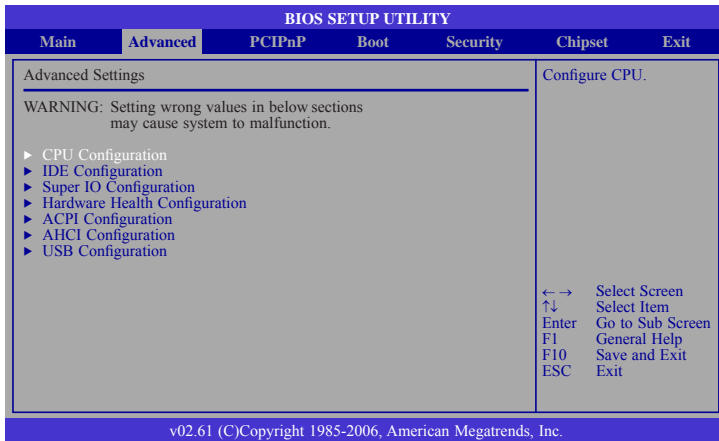

CPU Configuration

This section is used to configure the CPU. It will also display the detected CPU information.

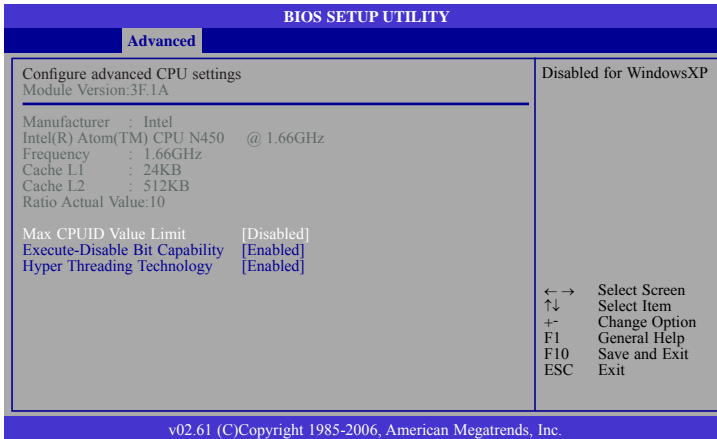

Max CPUID Value Limit

Set this field to Disabled when using Windows XP. Set this field to Enabled when using legacy operating systems so that the system will boot even when it doesn't support CPUs with extended CPUID function.

Execute-Disable Bit Capability

When this field is set to Disabled, it will force the XD feature flag to always return to 0.

Hyper Threading Technology

Enable this field for Windows XP and Linux which are optimized for Hyper-Threading technology. Select disabled for other OSes not optimized for Hyper-Threading technology. When disabled, only one thread per enabled core is enabled.

IDE Configuration

This section is used to configure the IDE drives.

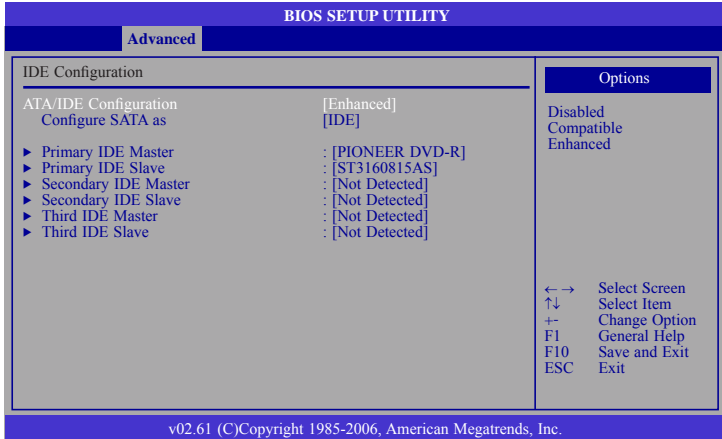

ATA/IDE Configuration

This field is used to configure the IDE drives. The options are Disabled, Compatible and Enhanced.

Configure SATA as

IDE

This option configures the Serial ATA drives as Parallel ATA storage devices.

AHCI

This option allows the Serial ATA devices to use AHCI (Advanced Host Controller Interface).

Primary IDE Master to Third IDE Slave

When you enter the BIOS Setup Utility, the BIOS will auto detect the existing IDE devices then displays the status of the detected devices. To configure an IDE drive, move the cursor to a field then press <Enter>.

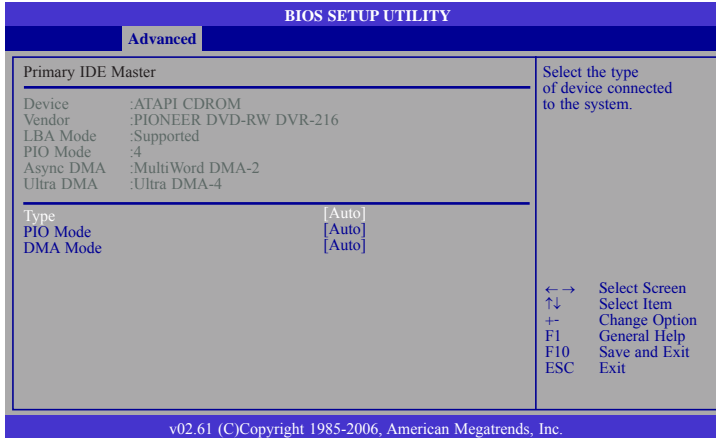

Type

Selects the type of IDE drive connected to the system.

PIO Mode

Selects the data transfer mode. PIO means Programmed Input/Output. Rather than have the BIOS issue a series of commands to effect a transfer to or from the disk drive, PIO allows the BIOS to tell the controller what it wants and then let the controller and the CPU perform the complete task by themselves. Your system supports five modes, 0 (default) to 4, which primarily differ in timing. When Auto is selected, the BIOS will select the best available mode after checking your drive.

Auto

The BIOS will automatically set the system according to your hard disk drive's timing.

Mode 0-4

You can select a mode that matches your hard disk drive's timing. Caution: Do not use the wrong setting or you will have drive errors.

DMA Mode

Selects the DMA mode.

Auto

Automatically detects the DMA mode.

SWDMAn

SingleWord DMAn.

MWDMAn

MultiWord DMAn.

UDMAn

Ultra DMAn.

Super IO Configuration

This section is used to configure the I/O functions supported by the onboard Super I/O chip.

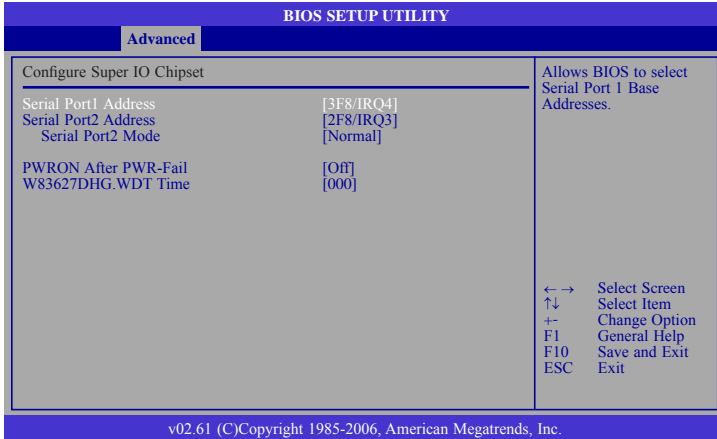

Serial Port1 Address and Serial Port2 Address

Auto

Automatically selects a base address for the COM port.

3F8/IRQ4, 2E8/IRQ3, 3E8/IRQ4

Selects the COM port's base address.

Disabled

Disables the COM port.

Serial Port2 Mode

COM port functions as a serial port or IrDA. You cannot use both at the same time.

Normal

Sets the COM port to serial port mode.

IrDA

Sets the COM port to IrDA mode.

ASK IR

Sets the COM port to ASK IR mode.

PWRON After PWR-Fail

Off

When power returns after an AC power failure, the system's power is off. You must press the Power button to power-on the system.

On

When power returns after an AC power failure, the system will automatically power-on.

Former-Sts

When power returns after an AC power failure, the system will return to the state where you left off before power failure occurs. If the system's power is off when AC power failure occurs, it will remain off when power returns. If the system's power is on when AC power failure occurs, the system will power-on when power returns.

W83627DHG.WDT Time

This field is used to select the time interval of the Watchdog timer. If the system hangs or fails to function, it will reset at the set time interval so that your system will continue to operate.

Hardware Health Configuration

This section is used to configure the hardware monitor function.

BIOS SETUP UTILITY		
Advanced		
Hardware Health Configuration		Enabled for Case Open Detection. If Case is open, system will show warning message and beep warning. ← → Select Screen ↑↓ Select Item + Change Option F1 General Help F10 Save and Exit ESC Exit
System Temperature	:48°C/118°F	
CPU Temperature	:60°C/140°F	
System Fan Speed	:NA	
CPU Fan Speed	:NA	
Vcore	:1.120 V	
+5(V)	:4.889 V	
+1.05(V)	:1.064V	
+1.8(V)	:1.840 V	
+12V	:12.091 V	
3VSB (V)	:3.360 V	
VBAT (V)	:3.120 V	
Case Open Detection	[Disabled]	
CPU Fan Mode Setting	[Manual Mode]	
CPU FAN PWM Control	[255]	
v02.61 (C)Copyright 1985-2006, American Megatrends, Inc.		

System Temperature to VBAT (V)

These fields will show the temperature, fan speed and output voltage of the monitored devices or components.

Case Open Detection

Set this field to Enabled to allow the system to alert you of a chassis intrusion event.

CPU Fan Mode Setting

Selects the CPU fan's mode. The options are Manual Mode and Thermal Cruise Mode.

CPU Fan PWM Control

This is the PWM's duty cycle control. Enter the CPU fan's speed in this field. The higher the value, the faster the CPU fan's speed.

ACPI Configuration

This section is used to configure ACPI.

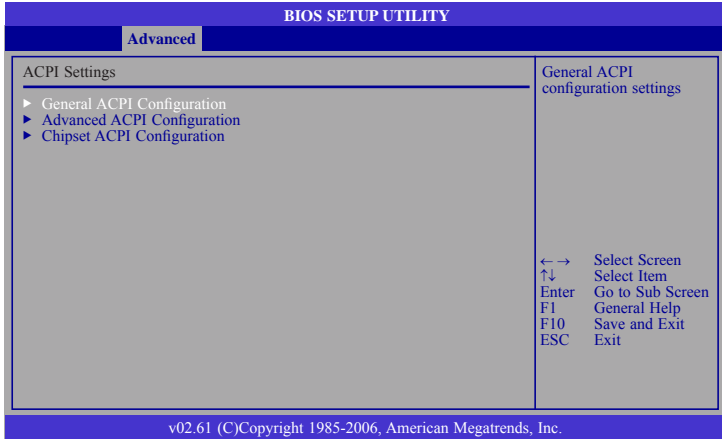

General ACPI Configuration

Configures the general ACPI settings.

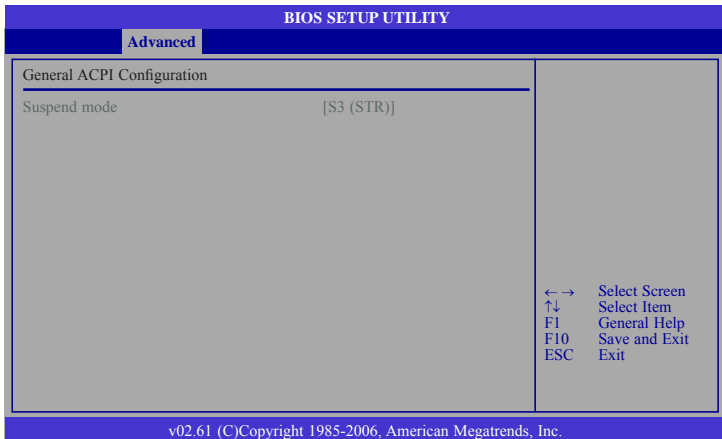

Suspend Mode*S3(STR)*

Enables the Suspend to RAM function.

Advanced ACPI Configuration

Configures additional ACPI functions.

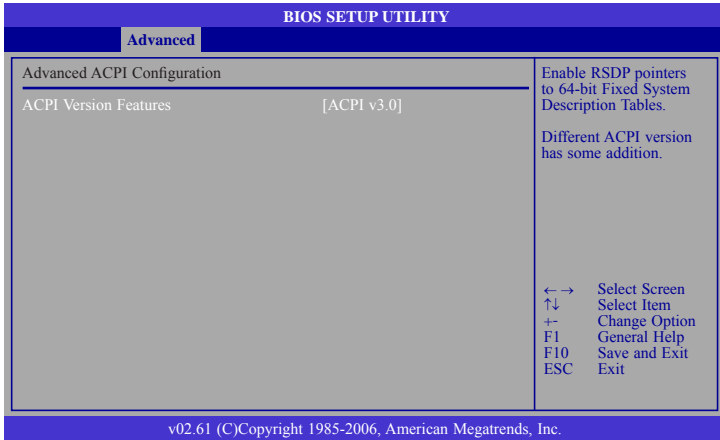

ACPI Version Features

Selects the ACPI version. The options are ACPI v1.0, ACPI v2.0 and ACPI v3.0.

Chipset ACPI Configuration

Configures relevant chipset ACPI functions.

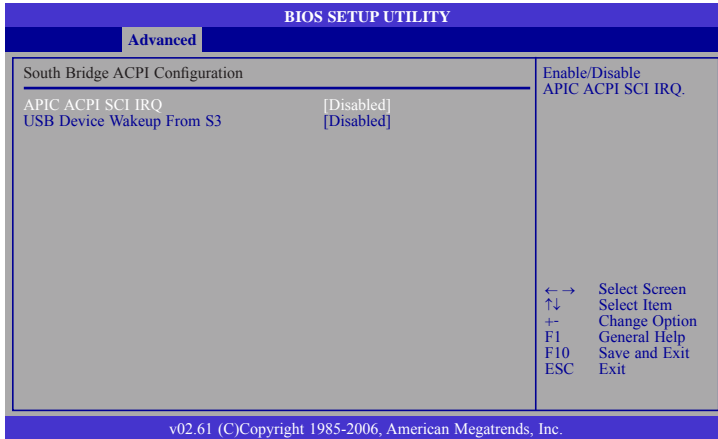

APIC ACPI SCI IRQ

Enables or disables the APIC ACPI SCI IRQ.

USB Device WakeUp From S3

This field, when enabled, allows you to use a USB keyboard to wake up a system that is in the S3 (STR - Suspend To RAM) and S4 state.

AHCI Configuration

This section is used to configure AHCI.

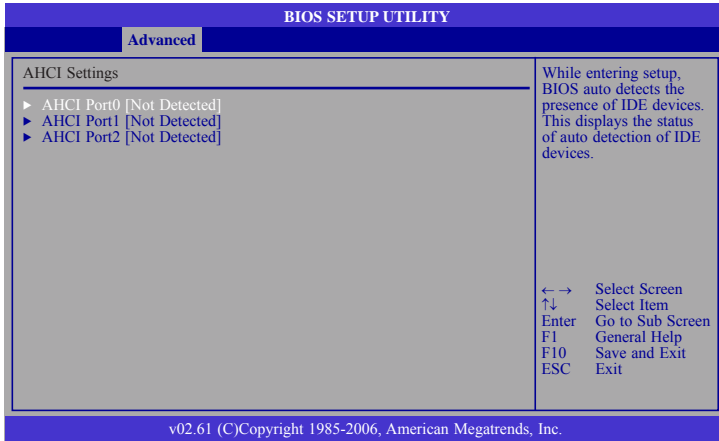

AHCI Port0 to AHCI Port2

Configures the AHCI port.

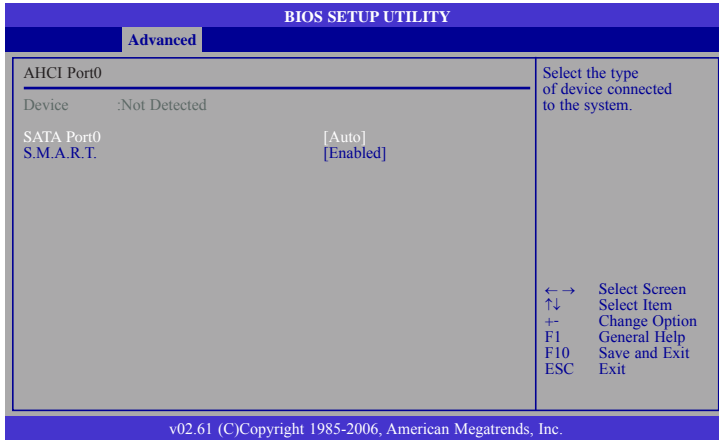

SATA Port0

Selects the type of device connected to the system.

S.M.A.R.T.

The system board supports SMART (Self-Monitoring, Analysis and Reporting Technology) hard drives. SMART is a reliability prediction technology for ATA/IDE and SCSI drives. The drive will provide sufficient notice to the system or user to backup data prior to the drive's failure. The default is Disabled. If you are using hard drives that support S.M.A.R.T., set this field to Enabled. SMART is supported in ATA/33 or later hard drives. The options are Auto, Enabled and Disabled.

USB Configuration

This section is used to configure USB devices.

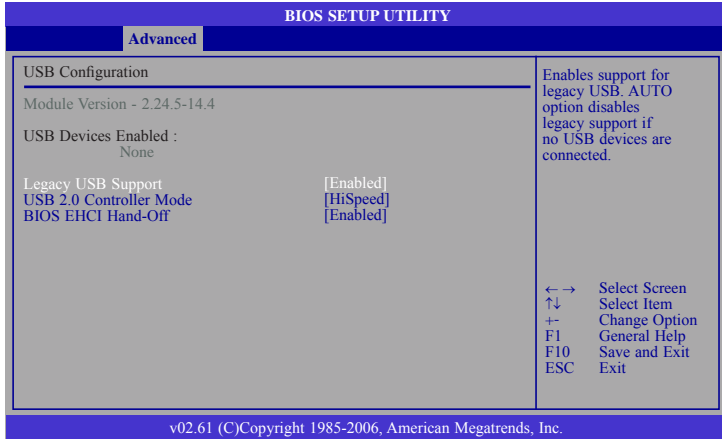

Legacy USB Support

Enabled

Enables Legacy USB.

Auto

Disables support for Legacy when no USB devices are connected.

Disabled

Keeps USB devices available only for EFI applications.

USB 2.0 Controller Mode

Configures the USB 2.0 controller in HiSpeed (480Mbps) or FullSpeed (12Mbps).

BIOS EHCI Hand-Off

This is a workaround for OSeS that does not support EHCI hand-off. The EHCI ownership change should be claimed by the EHCI driver.

PCIPnP

The PCIPnP menu is used to configure PCI Plug and Play devices.



Important:

Setting incorrect field values may cause the system to malfunction.

BIOS SETUP UTILITY						
Main	Advanced	PCIPnP	Boot	Security	Chipset	Exit
Advanced PCI/PnP Settings					Clear NVRAM during System Boot.	
WARNING: Setting wrong values in below sections may cause system to malfunction.						
Clear NVRAM			[No]			
Plug & Play O/S			[No]			
PCI Latency Timer			[64]			
IRQ3			[Available]			
IRQ4			[Available]			
IRQ5			[Available]			
IRQ7			[Available]			
IRQ9			[Available]			
IRQ10			[Available]			
IRQ11			[Available]			
IRQ14			[Available]			
IRQ15			[Available]			
					← → Select Screen ↑ ↓ Select Item + - Change Option F1 General Help F10 Save and Exit ESC Exit	
v02.61 (C)Copyright 1985-2006, American Megatrends, Inc.						

Clear NVRAM

This field allows clearing the NVRAM during system boot.

Plug & Play O/S

Yes

The operating system configures Plug and Play (PnP) devices that are not required to boot in a Plug and Play supported operating system.

No

The BIOS configures all the devices in the system.

PCI Latency Timer

This feature is used to select the length of time each PCI device will control the bus before another takes over. The larger the value, the longer the PCI device can retain control of the bus. Since each access to the bus comes with an initial delay before any transaction can be made, low values for the PCI Latency Timer will reduce the effectiveness of the PCI bandwidth while higher values will improve it.

IRQ3 to IRQ15

Available

The specified IRQ is available for PCI/PnP devices.

Reserved

The specified IRQ is reserved for Legacy ISA devices.

Boot

BIOS SETUP UTILITY						
Main	Advanced	PCIPnP	Boot	Security	Chipset	Exit
Boot Settings ▶ Boot Settings Configuration ▶ Boot Device Priority ▶ Hard Disk Drives ▶ CD/DVD Drives		Configure settings during system boot. ← → Select Screen ↑ ↓ Select Item Enter Go to Sub Screen F1 General Help F10 Save and Exit ESC Exit				
v02.61 (C)Copyright 1985-2006, American Megatrends, Inc.						

Boot Settings Configuration

This section is used to configure settings during system boot.

BIOS SETUP UTILITY		
Boot		
Boot Settings Configuration Quick Boot [Enabled] Full Screen Logo Display [Disabled] Bootup Num-Lock [On]		Allows BIOS to skip certain tests while booting. This will decrease the time needed to boot the system.
		← → Select Screen ↑ ↓ Select Item +/- Change Option F1 General Help F10 Save and Exit ESC Exit
v02.61 (C)Copyright 1985-2006, American Megatrends, Inc.		

Quick Boot

When Enabled, the BIOS will shorten or skip some check items during POST. This will decrease the time needed to boot the system.

Full Screen Logo Display

This field is applicable only if you want a particular logo to appear during system boot-up.

Enabled

Displays OEM logo instead of the POST messages.

Disabled

Displays normal POST messages.

Bootup Num-Lock

This allows you to determine the default state of the numeric keypad. By default, the system boots up with NumLock on wherein the function of the numeric keypad is the number keys. When set to Off, the function of the numeric keypad is the arrow keys.

Boot Device Priority

This section is used to select the boot priority sequence of the devices.

BIOS SETUP UTILITY	
Boot	
Boot Device Priority <hr/> 1st Boot Device [CD/DVD: PM-PIONEER] 2nd Boot Device [SATA: PS-ST3160815A] 3rd Boot Device [Network : Realtek PX]	Specifies the boot sequence from the available devices. A device enclosed in parenthesis has been disabled in the corresponding type menu. ← → Select Screen ↑ ↓ Select Item + - Change Option F1 General Help F10 Save and Exit ESC Exit
v02.61 (C)Copyright 1985-2006, American Megatrends, Inc.	

1st Boot Device to 3rd Boot Device

Selects the drive to boot first, second and third in the "1st Boot Device", "2nd Boot Device" or "3rd Boot Device" field. The BIOS will boot the operating system according to the sequence of the drive selected.

Hard Disk Drives

This section is used to select the boot priority sequence of the devices.

BIOS SETUP UTILITY	
Boot	
Hard Disk Drives	Specifies the boot sequence from the available devices.
Ist Drive [SATA: PS-ST3160815A]	
	←→ Select Screen ↑↓ Select Item + Change Option F1 General Help F10 Save and Exit ESC Exit
v02.61 (C)Copyright 1985-2006, American Megatrends, Inc.	

CD/DVD Drives

This section is used to select the boot priority sequence of the devices.

BIOS SETUP UTILITY	
Boot	
CD/DVD Drives	Specifies the boot sequence from the available devices.
1st Drive [CD/DVD: PM-PIONEER]	
	← → Select Screen ↑↓ Select Item + Change Option F1 General Help F10 Save and Exit ESC Exit
v02.61 (C)Copyright 1985-2006, American Megatrends, Inc.	

Security

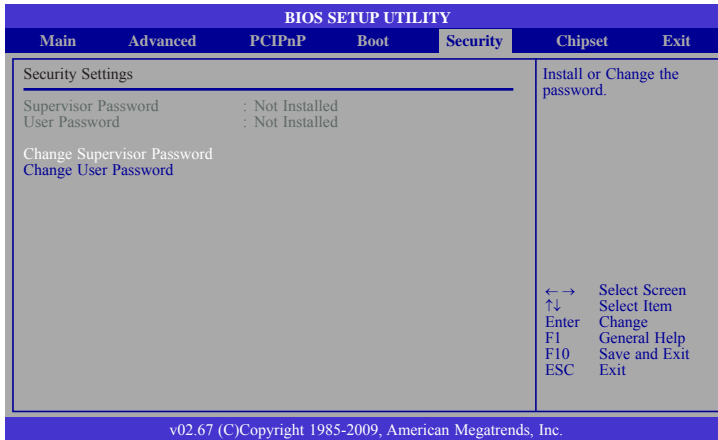

Change Supervisor Password

This field is used to set or change the supervisor password. To set a new password:

1. Select the Change Supervisor Password field then press <Enter>.
2. Type your password in the dialog box then press <Enter>. You are limited to eight letters/numbers.

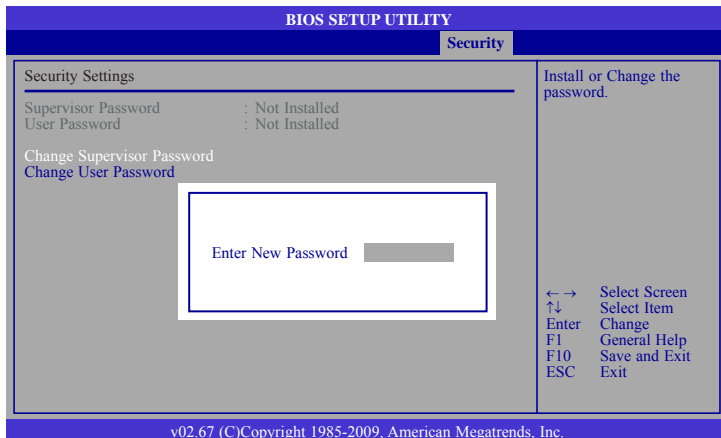

3. Press <Enter> to confirm the new password.

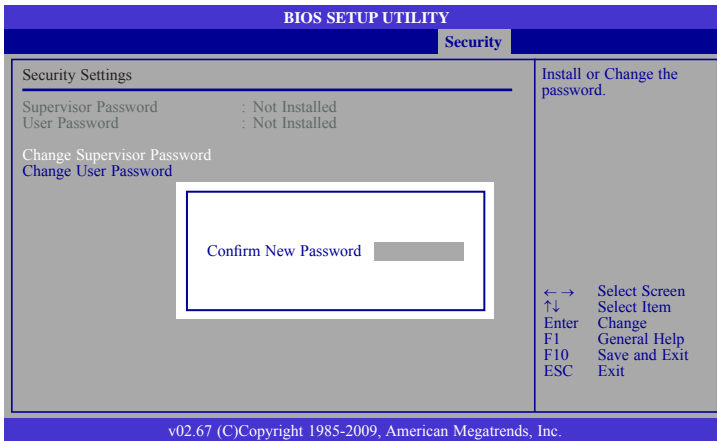

4. When the Password Installed dialog box appears, click OK.

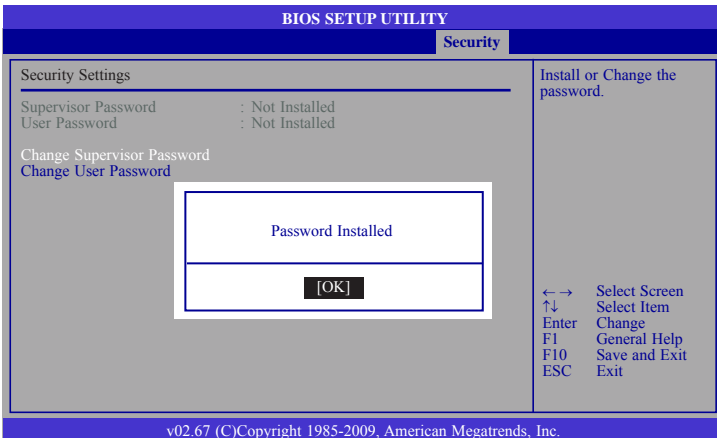

To change the password, repeat the same steps above.

To clear the password, select Change Supervisor Password then press <Enter>. The Password Uninstalled dialog box will appear.

If you forgot the password, you can clear the password by erasing the CMOS RTC (Real Time Clock) RAM using the Clear CMOS jumper. Refer to the Jumper Settings section in chapter 2 for more information.

After you have set the supervisor password, the User Access Level field will appear.

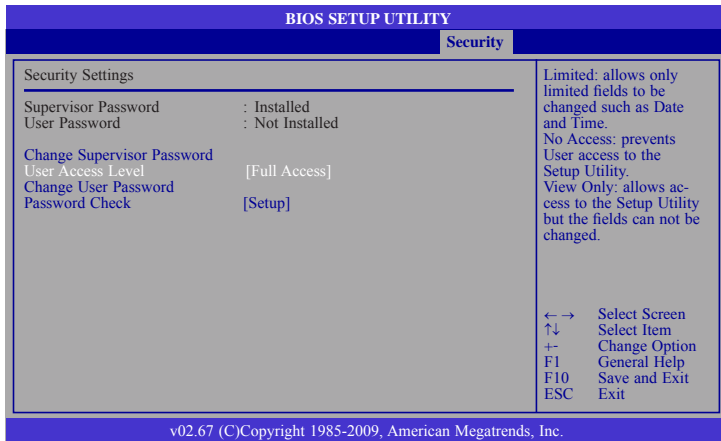

User Access Level

Selects the access level to the fields in the Setup utility.

Limited

Allows limited change to some fields such as Date and Time.

No Access

Prevents user access to the Setup utility.

View Only

Allows you to view the settings but does not allow you to change the settings.

Full Access

Allows you to change settings to all the fields in the utility.

Change User Password

This field is used to set or change the user password.

To set a new password:

1. Select the Change User Password field then press <Enter>.
2. Type your password in the dialog box then press <Enter>. You are limited to eight letters/numbers.

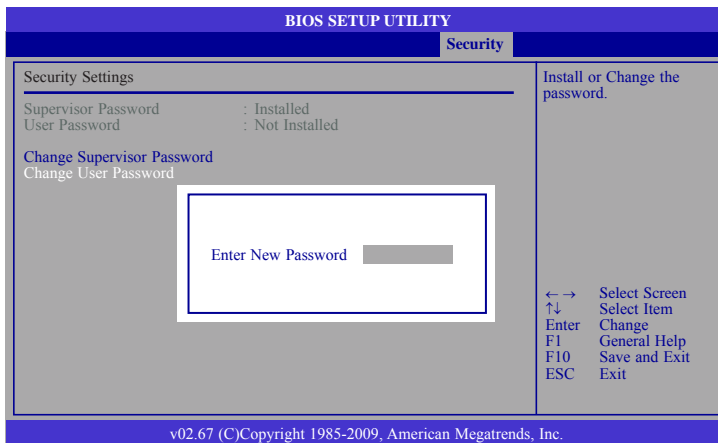

3. Press <Enter> to confirm the new password.

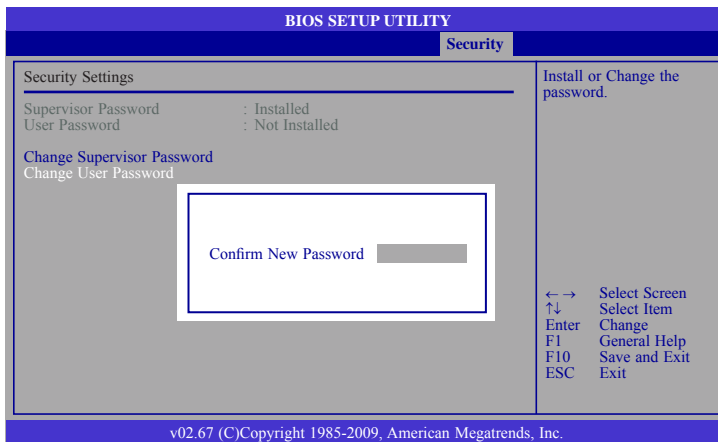

4. When the Password Installed dialog box appears, select OK.

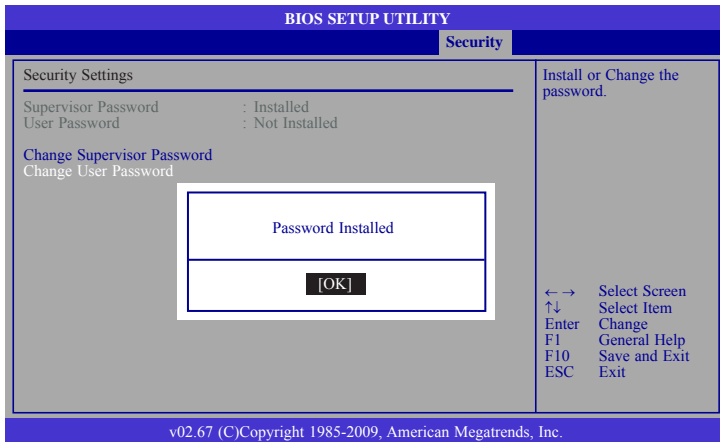

To change the password, repeat the same steps above.

After you have set the user password, the Clear User Password and Password Check fields will appear.

Clear User Password

To clear the password, select Clear User Password then press <Enter>. Click OK.

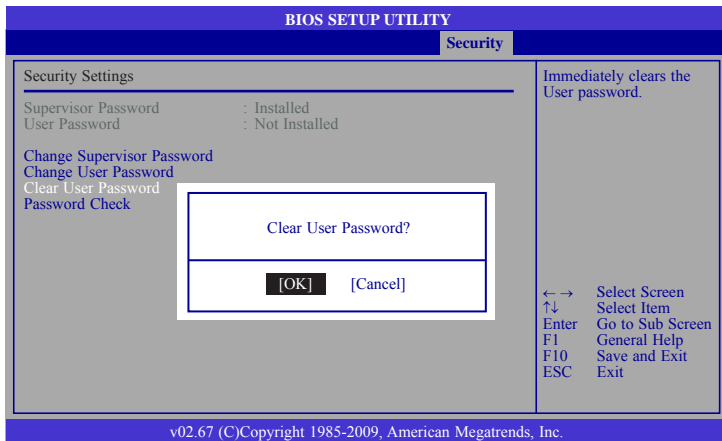

Password Check

Setup

The BIOS checks for the user password whenever accessing the Setup utility.

Always

The BIOS checks for the user password when accessing the Setup utility and booting the system.

Chipset

This section is used to configure the system based on the specific features of the chipset.



Important: Setting incorrect field values may cause the system to malfunction.

BIOS SETUP UTILITY						
Main	Advanced	PCIPnP	Boot	Security	Chipset	Exit
Advanced Chipset Settings <hr/> WARNING: Setting wrong values in below sections may cause system to malfunction. ▶ North Bridge Configuration ▶ South Bridge Configuration					Configure North Bridge features. ← → Select Screen ↑ ↓ Select Item Enter Go to Sub Screen F1 General Help F10 Save and Exit ESC Exit	
v02.61 (C)Copyright 1985-2006, American Megatrends, Inc.						

North Bridge Configuration

BIOS SETUP UTILITY		
		Chipset
North Bridge Chipset Configuration <hr/> PCI MMIO Allocation: 4GB to 3072MB Initiate Graphic Adapter [IGD] Internal Graphics Mode Select [Enabled, 8MB] ▶ Video Function Configuration		Select which graphics controller to use as the primary boot device. ← → Select Screen ↑ ↓ Select Item + - Change Option F1 General Help F10 Save and Exit ESC Exit
v02.61 (C)Copyright 1985-2006, American Megatrends, Inc.		

Initiate Graphics Adapter

Selects the graphics controller to use as the primary boot device.

Internal Graphics Mode Select

Selects the amount of system memory used by the internal graphics device.

Video Function Configuration

BIOS SETUP UTILITY		Chipset
Video Function Configuration		Options
DVMT Mode Select	[DVMT Mode]	Fixed Mode
DVMT/FIXED Memory	[256MB]	DVMT Mode
Boot Display Device	[VBIOS-Default]	
Flat Panel Type	[3 :1024x768, 18bit]	
		← → Select Screen
		↑ ↓ Select Item
		+ - Change Option
		F1 General Help
		F10 Save and Exit
		ESC Exit
v02.61 (C)Copyright 1985-2006, American Megatrends, Inc.		

DVMT Mode Select

DVMT Mode

Memory that is dynamically allocated based on memory requests made by an application and are released back to the system once the requesting application has been terminated.

Fixed Mode

Non-contiguous pagelocked memory allocated during driver initialization to provide a static amount of memory.

DVMT/FIXED Memory

Selects the graphics memory size used by the DVMT/Fixed mode.

Boot Display Device

Selects the type of display to use when the system boots.

Flat Panel Type

Selects the type of flat panel connected to the system.

South Bridge Configuration

BIOS SETUP UTILITY		Chipset
South Bridge Chipset Configuration		Options
USB Functions	[10 USB Ports]	Disabled
USB 2.0 Controller	[Enabled]	2 USB Ports
HDA Controller	[Enabled]	4 USB Ports
		6 USB Ports
		8 USB Ports
		10 USB Ports
PCIE Ports Configuration		
PCIE1 Slot	[Enabled]	
Onboard LAN	[Enabled]	
		← → Select Screen
		↑↓ Select Item
		+ - Change Option
		F1 General Help
		F10 Save and Exit
		ESC Exit
v02.61 (C)Copyright 1985-2006, American Megatrends, Inc.		

USB Functions

Selects the number of USB ports you want enabled.

USB 2.0 Controller

Enables or disables the Enhanced Host Controller Interface (USB 2.0).

HDA Controller

Enables or disables the High Definition audio controller.

PCIE1 Slot

Enables or disables the PCIE x1 slot.

Onboard LAN

Enables or disables the LAN controller.

Exit

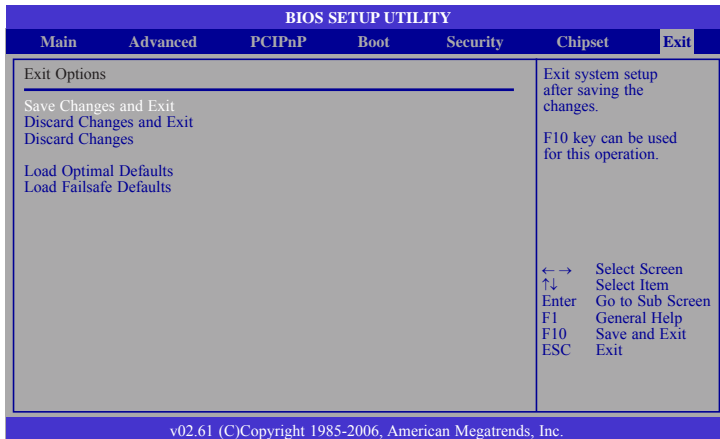

Save Changes and Exit

To save the changes and exit the Setup utility, select this field then press <Enter>. A dialog box will appear. Confirm by selecting OK.

You can also press <F10> to save and exit Setup.

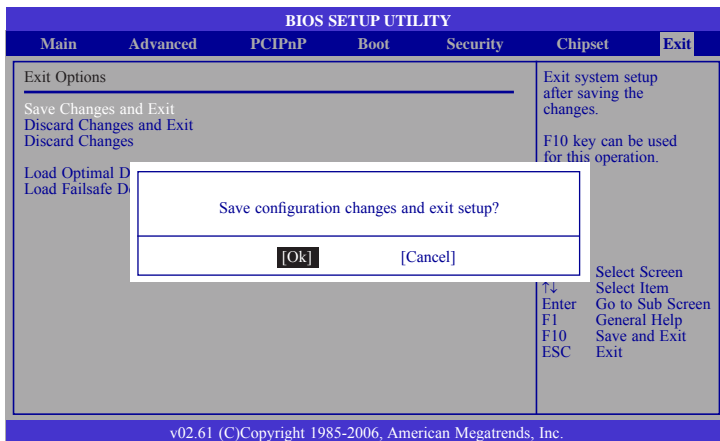

Discard Changes and Exit

To exit the Setup utility without saving the changes, select this field then press <Enter>. A dialog box will appear. Confirm by selecting OK.

You can also press <ESC> to exit without saving the changes.

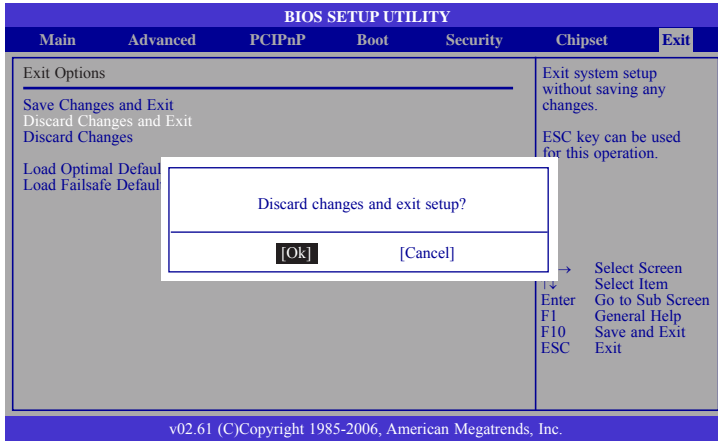

Discard Changes

To discard the changes, select this field then press <Enter>. A dialog box will appear. Confirm by selecting OK to discard all changes made and restore the previously saved settings.

You can also press <F7> to discard the changes.

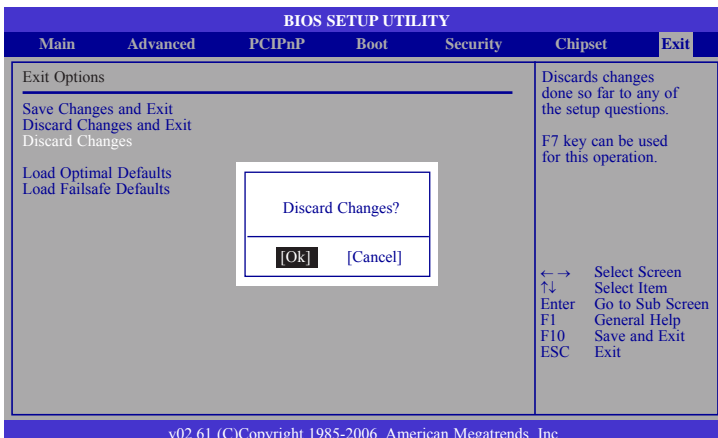

Load Optimal Defaults

To load optimal default values from the BIOS ROM, select this field then press <Enter>. A dialog box will appear. Confirm by selecting OK.

You can also press <F9> to load optimal default values.

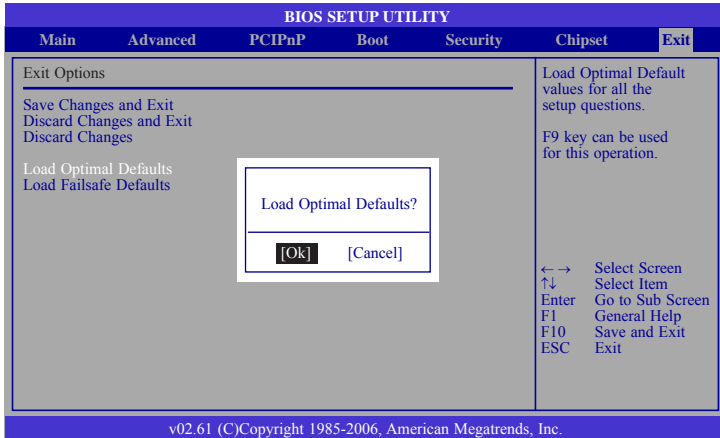

Load Failsafe Defaults

To load the fail-safe default values from the BIOS ROM, select this field then press <Enter>. A dialog box will appear. Confirm by selecting OK.

You can also press <F8> to load the fail-safe default values.

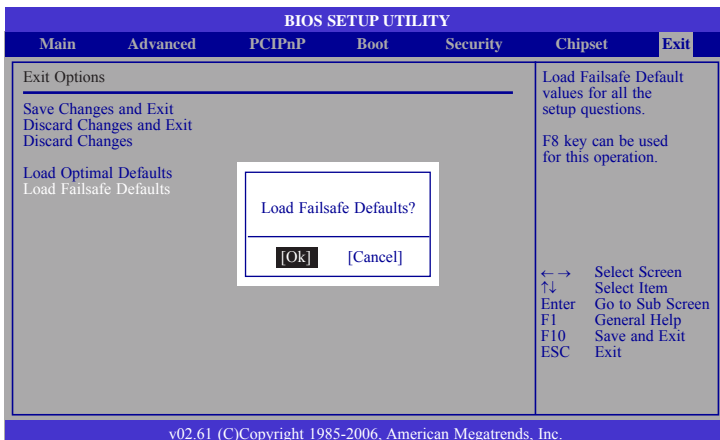

Updating the BIOS

To update the BIOS, you will need the new BIOS file and a flash utility, AFUDOS.EXE. Please contact technical support or your sales representative for the files.

To execute the utility, type:

```
A:> AFUDOS BIOS_File_Name /b /p /n /c
```

then press <Enter>.

```
[C:\LANID\INTEL]>AFUDOS filename.ROM /B /P /N /C
+-----+
|               AMI Firmware Update Utility v4.33               |
|      Copyright (C) 2009 American Megatrends Inc. All Rights Reserved.      |
+-----+
- Bootblock checksum ..... ok
- Module checksums ..... ok
- Erasing flash ..... done
- Writing flash ..... done
- Verifying flash ..... done
- Erasing NVRAM ..... done
- Writing NVRAM ..... done
- Verifying NVRAM ..... done
- Erasing Bootblock ..... done
- Writing Bootblock ..... done
- Verifying Bootblock ..... done
- CMOS checksum destroyed
- Program ended normally.

[C:\LANID\INTEL]>
```

Chapter 4 - Supported Software

Drivers for Windows 7 / Windows Vista System

The CD that came with the board contains drivers, utilities and software applications required to enhance the performance of the system board. Insert the CD into a CD-ROM drive. The autorun screen (Mainboard Utility CD) will appear. If after inserting the CD, "Autorun" did not automatically start, please go directly to the root directory of the CD and double-click "Setup".



Intel Chipset Software Installation Utility

The Intel Chipset Software Installation Utility is used for updating Windows INF files so that the Intel chipset can be recognized and configured properly in the system.

To install the utility, click “Intel Chipset Software Installation Utility” on the main menu.

1. Setup is now ready to install the utility. Click Next.



2. Read the license agreement then click Yes.



3. Go through the readme document for system requirements and installation tips then click Next.



5. After completing installation, click Finish to exit setup.



Intel Graphics Drivers

To install the driver, click “Intel Graphics Drivers” on the main menu.

1. Setup is now ready to install the graphics driver. Click Next.

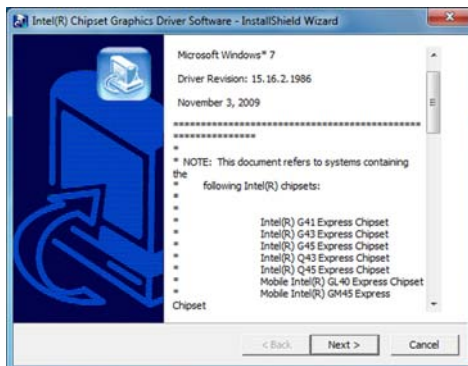

By default, the “Automatically run WinSAT and enable the Windows Aero desktop theme” is enabled. With this enabled, after installing the graphics driver and the system rebooted, the screen will turn blank for 1 to 2 minutes (while WinSAT is running) before the Windows 7 / Windows Vista desktop appears. The “blank screen” period is the time Windows is testing the graphics performance.

We recommend that you skip this process by disabling this function then click Next.



2. Read the license agreement then click Yes.



3. Go through the readme document for system requirements and installation tips then click Next.

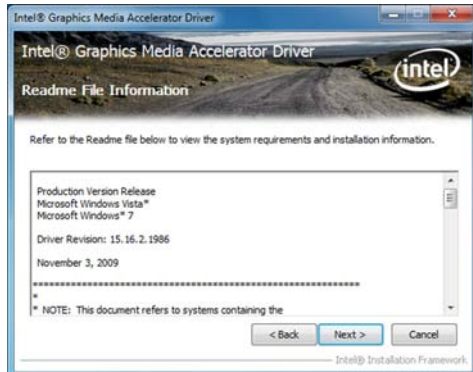

4. Setup is now installing the driver. Click Next to continue.

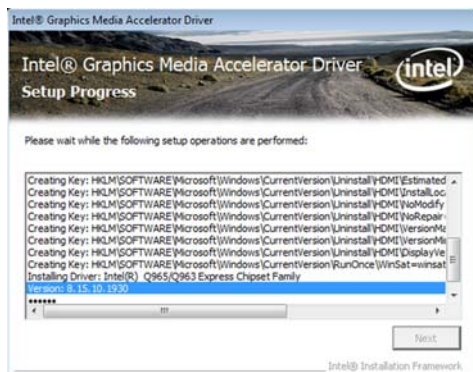

5. Click “Yes, I want to restart this computer now” then click Finish.

Restarting the system will allow the new software installation to take effect.



S3 Graphics Drivers

To install the driver, click “S3 Graphics Drivers” on the main menu.

1. The installation program is ready to install the graphics driver. Click Next.



2. Click Next.



3. The installation program is currently installing the driver. Follow the remainder of the steps to complete the installation.



Realtek LAN Drivers

To install the driver, click “Realtek LAN Drivers” on the main menu.

1. Setup is ready to install the driver. Click Next.

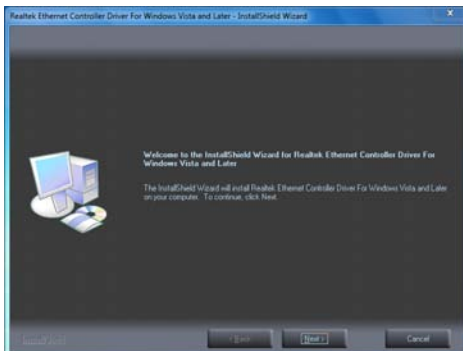

2. Click Install to begin the installation.

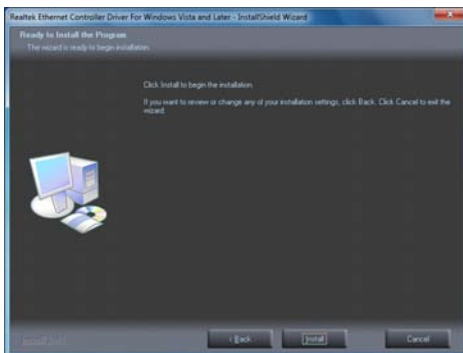

3. After completing installation, click Finish.

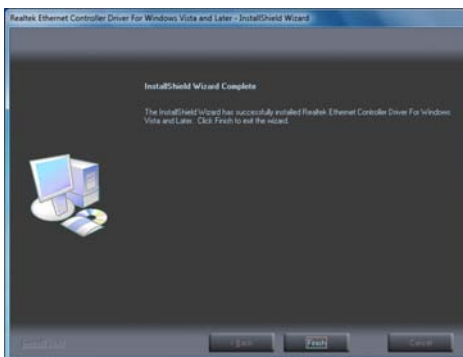

Audio Drivers

To install the driver, click “Audio Drivers” on the main menu.

1. Setup is now ready to install the driver. Click Next.
2. Follow the remainder of the steps on the screen; clicking “Next” each time you finish a step.



3. Click “Yes, I want to restart my computer now” then click Finish.

Restarting the system will allow the new software installation to take effect.



Hardware Monitor for Windows

The Hardware Monitor for Windows utility is capable of monitoring the system's temperature, fan speed, voltage, etc. and allows you to manually set a range (Highest and Lowest Limit) to the items being monitored. If the settings/values are over or under the set range, a warning message will pop-up. The utility can also be configured so that a beeping alarm will sound whenever an error occurs. We recommend that you use the "Default Setting" which is the ideal setting that would keep the system in good working condition.

To install the utility, click "Hardware Monitor for Windows" on the main menu.

1. Setup is now ready to install the utility. Click Next.

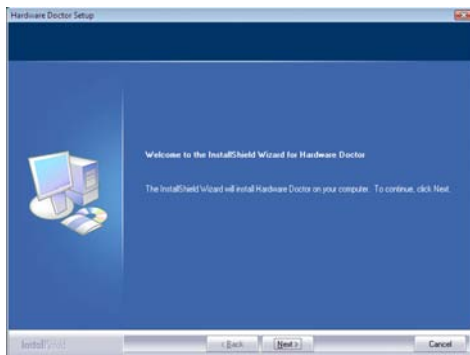

2. Click Next to install or click Browse to select another folder.

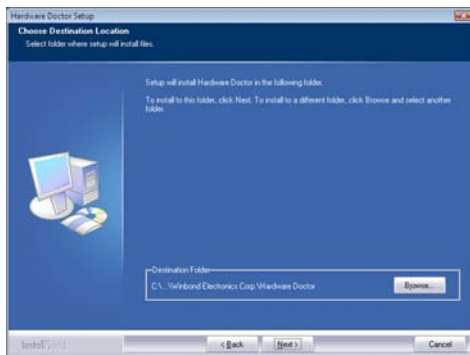

- Click Next to add the program icon to the Program Folder.

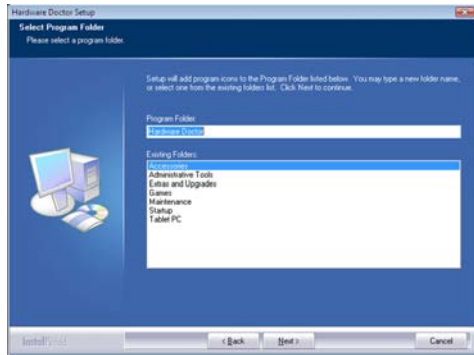

- After completing installation, click Finish to exit setup.

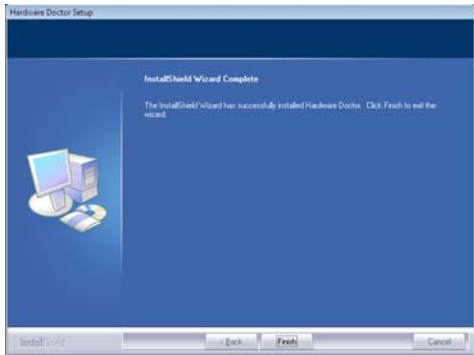

- Click Yes if you want to create a Hardware Doctor shortcut at your desktop.

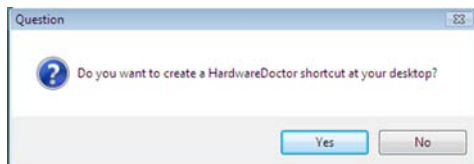

- Click “Yes, I want to restart my computer now” then click Finish.

Restarting the system will allow the utility to take effect.



Using the Hardware Monitor for Windows Utility

1. On your desktop, right-click the Hardware Doctor icon and then select Properties.

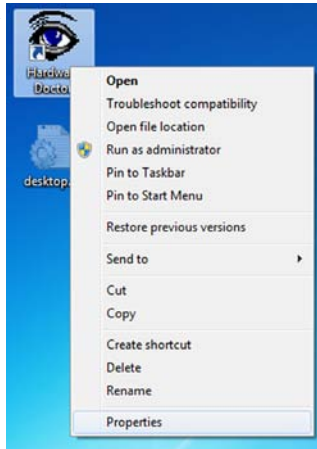

2. Select the Compatibility tab, click "Run this program as an administrator" then click OK.

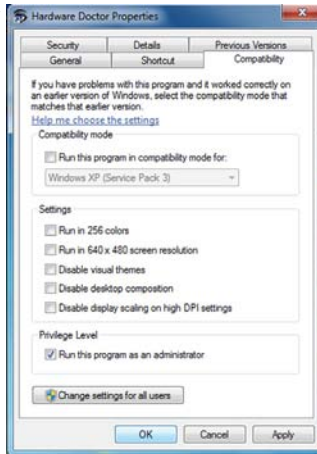

4

Supported Software

4. You can now access the utility.

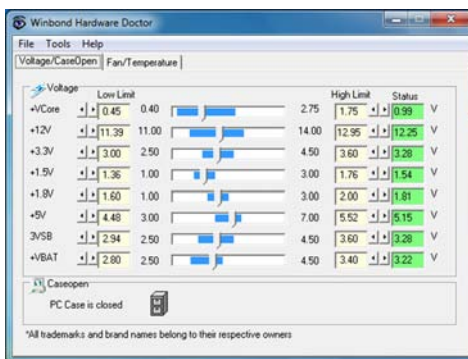

Intel Matrix Storage Manager Utility

Intel Matrix Storage Manager is a utility that allows you to monitor the current status of the SATA drives. It enables enhanced performance and power management for the storage subsystem.

To install the utility, click “Intel Matrix Storage Manager Utility” on the main menu.

1. Setup is now ready to install the utility. Click Next.



2. Read the license agreement then click Yes.



- Go through the readme document for system requirements and installation tips then click Next.

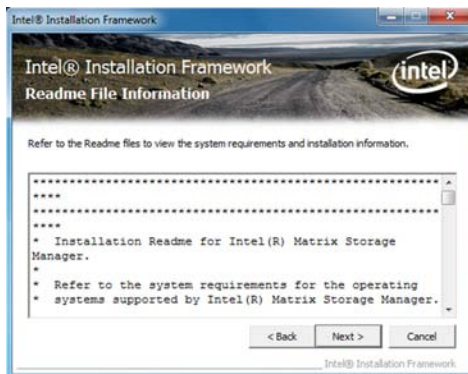

- Setup is now installing the utility. Click Next to continue.

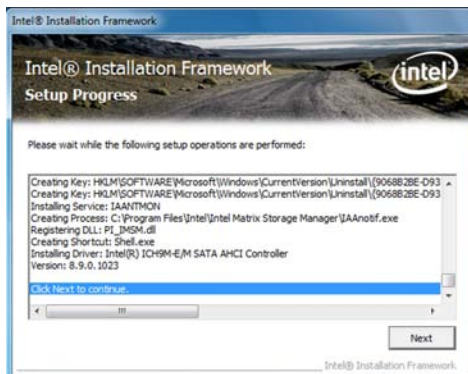

- Click "Yes, I want to restart my computer now" then click Finish.

Restarting the system will allow the new software installation to take effect.

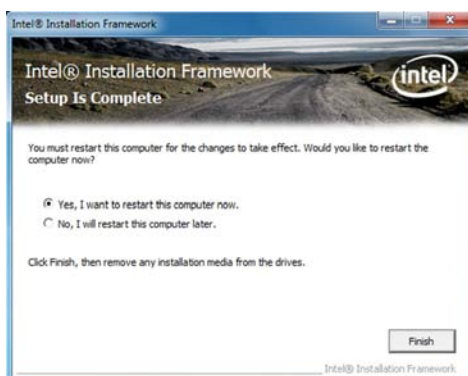

6. Run the Intel Matrix Storage Console utility to view the hard drives' configuration.

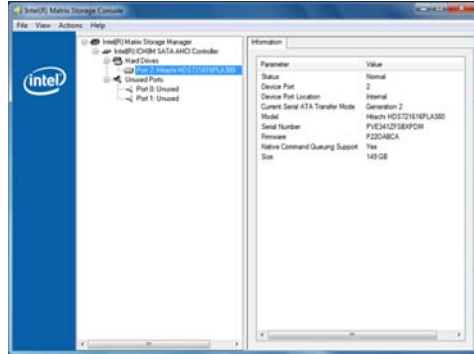

AHCI For F6 During Windows Setup Floppy Driver

You need to prepare an AHCI driver floppy diskette that you will need when you install the AHCI driver during Windows 7 / Windows Vista installation. You may also choose to copy the installation files to a USB flash drive.

1. Click "AHCI For F6 During Windows Setup Floppy Driver" on the main menu.

Windows Explorer will appear showing the locations of the installation files.

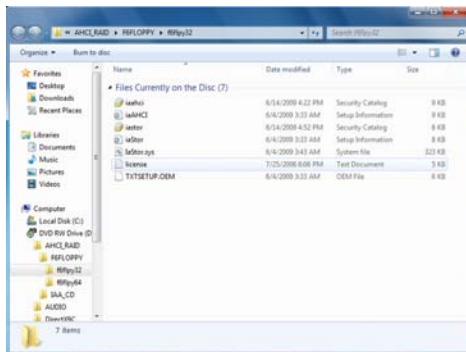

2. Click the Organize menu then click "Select All".
3. Insert a blank formatted floppy diskette into a floppy disk drive or plug a USB flash drive.

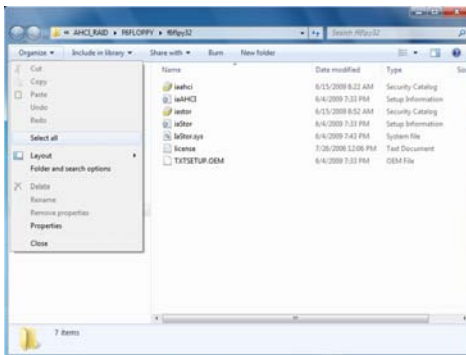

4. Right click on the files, select "Send To" and then select the floppy drive or USB flash drive.

The system will copy the selected files to the designated drive.

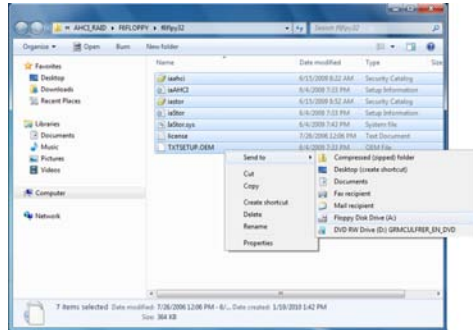

Installing the AHCI Driver During Windows 7 / Windows Vista Installation

The AHCI driver must be installed during Windows 7 / Windows Vista installation. This is required in order to be able to install the operating system onto a hard drive that is configured in AHCI mode.

**Note:**

The illustrations below were captured from the Windows 7 operating system. Except for slight differences in their screen appearance, the installation procedure is also the same for Windows Vista.

When you insert the operating system's installation disc into an optical drive, the message **Press any key to boot from CD or DVD** will appear. Press Enter.

1. Enter the preferred language and other preferences then click Next.



2. Click Install Now.



- Click "I accept the license terms" then click Next.

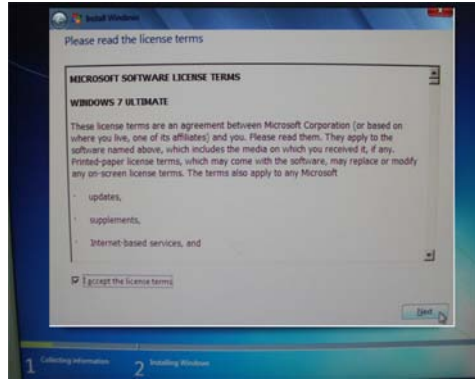

- Click Custom (advanced) to install a new copy of Windows.

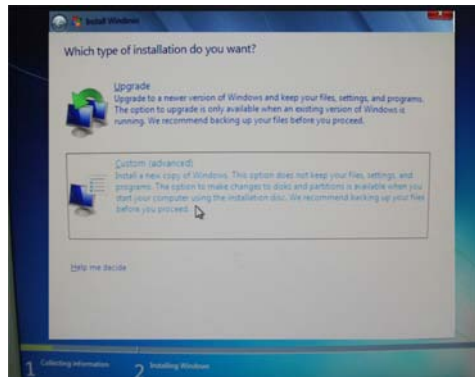

- Select Load Driver then click Next.

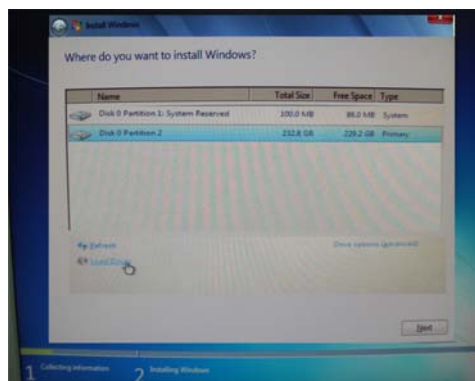

- If you are using one optical drive only, take out the Windows installation disc and then insert the CD that came with the motherboard package.

If you have another optical drive, you can choose to insert the provided CD to that drive or plug the USB flash drive that contains the AHCI driver.

Click Browse.

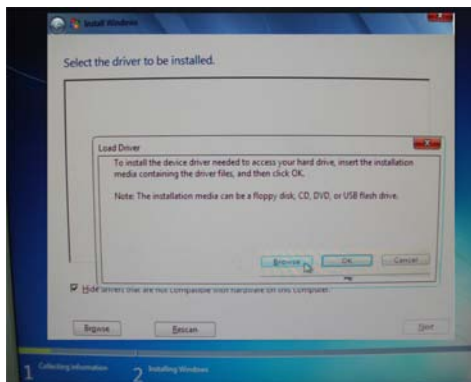

- Locate for the optical drive where you inserted the CD. The AHCI driver is in the \AHCI_RAID\F6FLOPPY\F6FLPY32 of the CD.

Or locate for the USB flash drive that contains the AHCI driver.

After you have selected the driver, click OK.

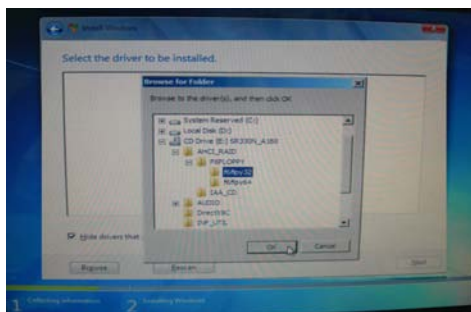

- Select the driver then click Next.



9. If you are using one optical drive only, the warning message “Windows cannot be installed to this disk” will appear. Remove the AHCI driver CD and insert the Windows installation disc back in. You will not be able to proceed yet because the Next button is still gray. You must first click Refresh.

Skip this step if the CD is in another optical drive or if you are using a USB flash drive.

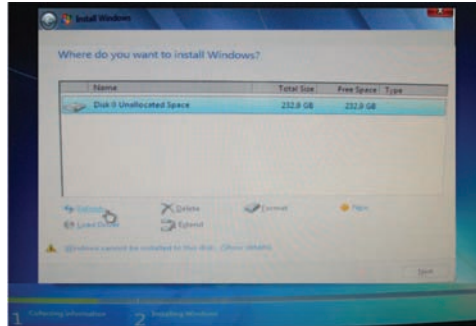

10. The Next button that was initially gray will turn black. Click Next to proceed.

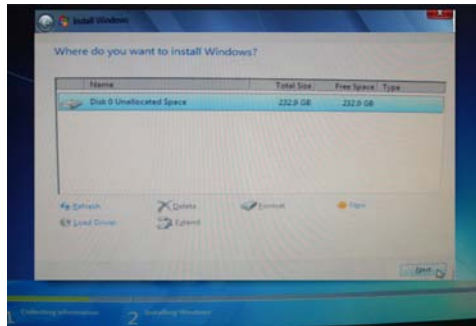

11. The system is currently installing Windows. Your computer will restart several times during the installation.

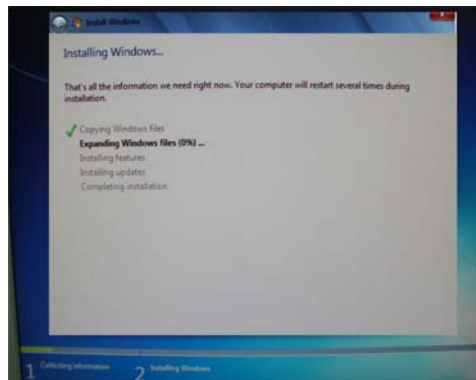

Infineon TPM Driver

To install, click "Infineon TPM Driver" on the main menu.

1. The setup program is preparing to install the driver.

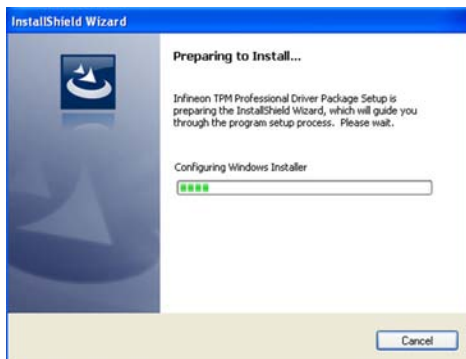

2. The driver has been successfully installed. Click Finish.



Infinion TPM Utility

To install, click “Infinion TPM Utility” on the main menu.

1. TPM requires installing the Microsoft Visual C++ package prior to installing the utility. Click Install.

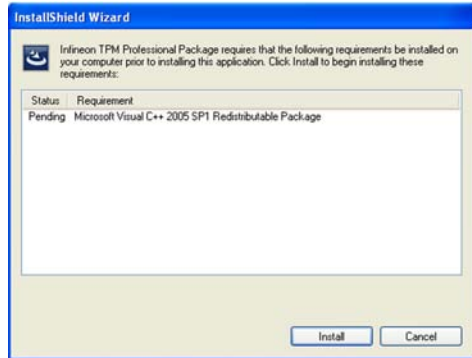

2. The setup program is currently installing the Microsoft Visual C++ package.

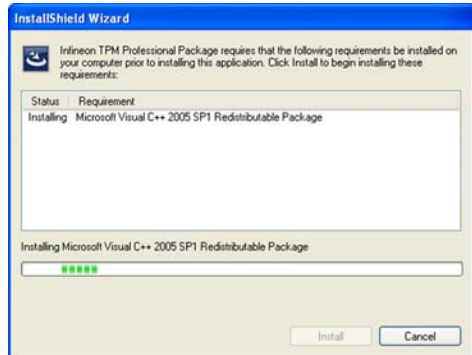

3. The setup program is now ready to install the utility. Click Next.



- Click "I accept the terms in the license agreement" and then click "Next".



- Enter the necessary information and then click Next.

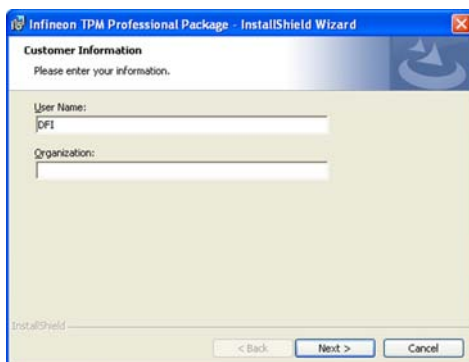

- Select a setup type and then click Next.



7. Click Install.



8. Click Finish.



Adobe Acrobat Reader 9.3

To install, click “Adobe Acrobat Reader 9.3” on the main menu.

1. Click Next to install to the destination folder or click Change Destination folder to select another folder.



2. Click Install to begin installation.

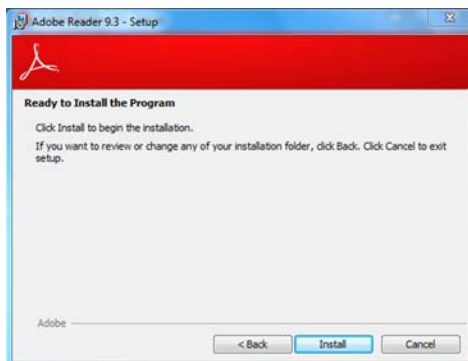

3. Click Finish to exit installation.

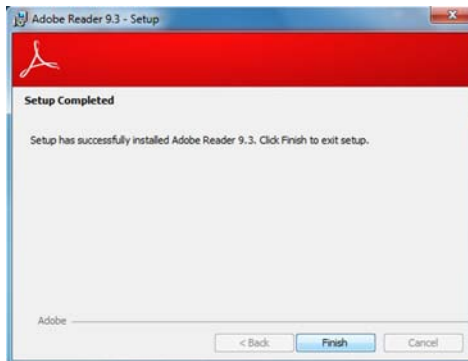

Drivers for Windows XP System

The CD that came with the system board contains drivers, utilities and software applications required to enhance the performance of the system board. Insert the CD into a CD-ROM drive. The autorun screen (Main Board Utility CD) will appear. If after inserting the CD, "Autorun" did not automatically start, please go directly to the root directory of the CD and double-click "Setup".



Intel Chipset Software Installation Utility

The Intel Chipset Software Installation Utility is used for updating Windows® INF files so that the Intel chipset can be recognized and configured properly in the system.

To install the utility, click "Intel Chipset Software Installation Utility" on the main menu.

1. Setup is ready to install the utility. Click Next.



2. Read the license agreement then click Yes.



- Go through the readme document for more installation tips then click Next.



- After all setup operations are done, click Next.



- Click Finish to exit setup.



Intel Graphics Drivers

To install the driver, click “Intel Graphics Drivers” on the main menu.

1. To start installation, click Next.



2. Read the license agreement then click Yes.

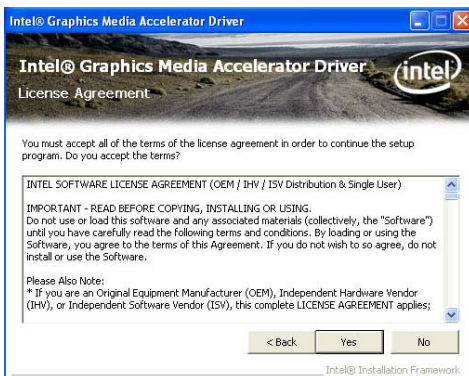

3. Go through the readme document for system requirements and installation tips then click Next.

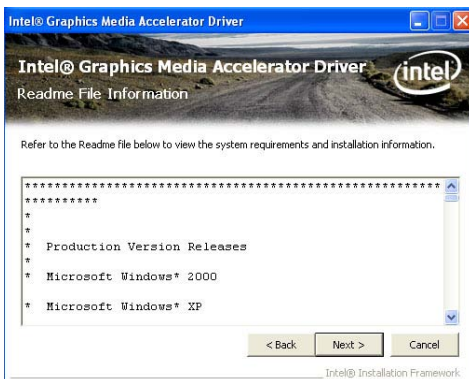

4. Setup is now installing the driver. Click Next to continue.

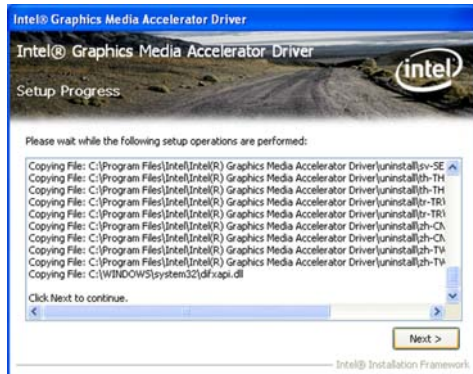

5. Click "Yes, I want to restart this computer now" then click Finish.

Restarting the system will allow the new software installation to take effect.

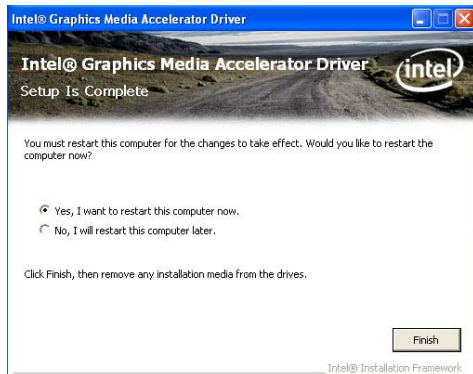

S3 Graphics Drivers

To install the driver, click “S3 Graphics Drivers” on the main menu.

1. The installation program is ready to install the graphics driver. Click Next.



2. Click Next.



3. The installation program is currently installing the driver. Follow the remainder of the steps to complete the installation.



Realtek LAN Drivers

To install the driver, click “Realtek LAN Drivers” on the main menu.

1. Setup is ready to install the driver. Click Next.

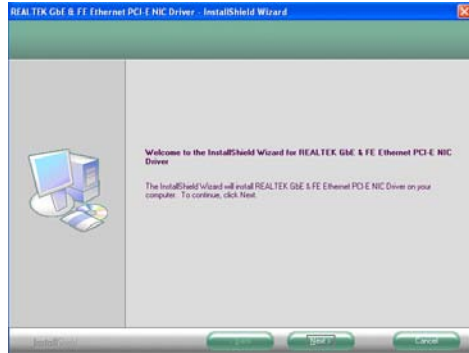

2. Click Install to begin the installation.

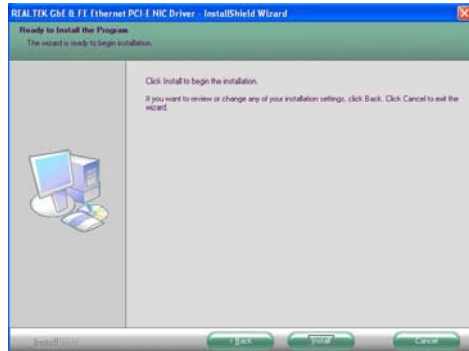

3. After completing installation, click Finish.

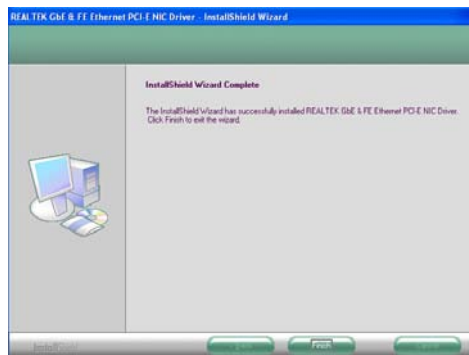

Audio Drivers

To install the driver, click “Audio Drivers” on the main menu.

1. Setup is ready to install the driver. Click Next.

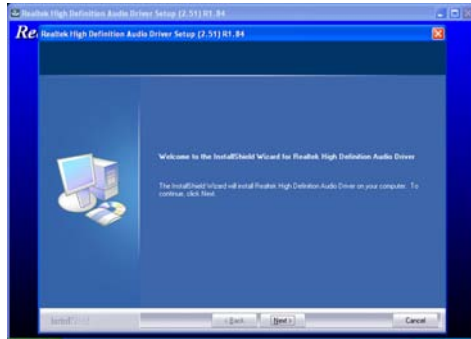

2. Click “Yes, I want to restart my computer now” then click Finish.

Restarting the system will allow the new software installation to take effect.

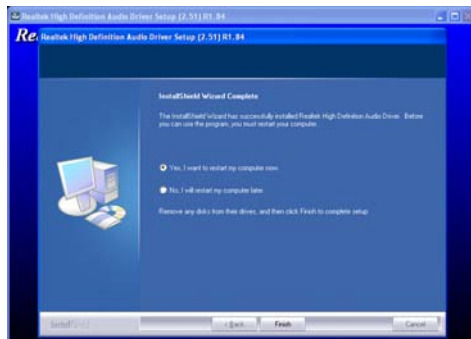

Hardware Monitor for Windows

The Hardware Monitor for Windows utility is capable of monitoring the system's temperature, fan speed, voltage, etc. and allows you to manually set a range (Highest and Lowest Limit) to the items being monitored. If the settings/values are over or under the set range, a warning message will pop-up. The utility can also be configured so that a beeping alarm will sound whenever an error occurs. We recommend that you use the "Default Setting" which is the ideal setting that would keep the system in good working condition.

To install, click "Hardware Monitor for Windows" on the main menu.

1. Setup is now ready to install the utility. Click Next.



2. Click Next to install or click Change to select another folder.



- Click Install to begin the installation.

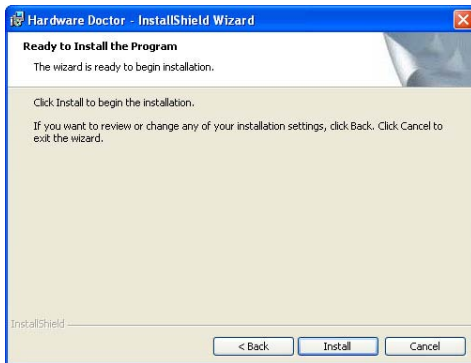

- After completing installation, click Finish.



Intel Matrix Storage Manager Utility

Intel Matrix Storage Manager is a utility that allows you to monitor the current status of the SATA drives. It enables enhanced performance and power management for the storage subsystem.



Note:

This utility is supported only when the SATA Mode field is set to AHCI. (The SATA Mode field is in the OnChip IDE Device section, Integrated Peripherals submenu of the BIOS utility.)

To install the utility, click “Intel Matrix Storage Manager Utility” on the main menu.

1. Setup is now ready to install the utility. Click Next.

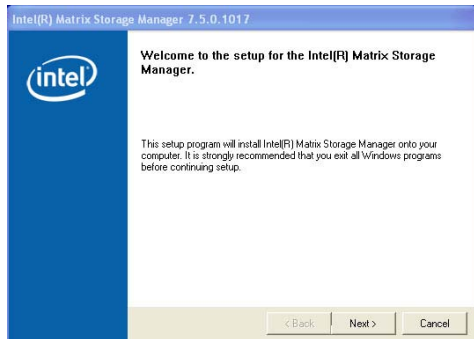

2. Read the Warning information carefully then click Next.



3. Read the license agreement then click Yes.



4. Go through the readme document for system requirements and installation tips then click Next.

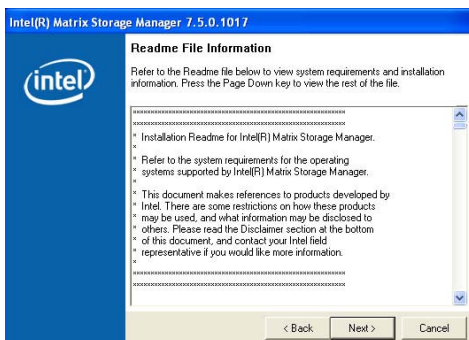

5. Click "Yes, I want to restart my computer now" then click Finish.

Restarting the system will allow the new software installation to take effect.

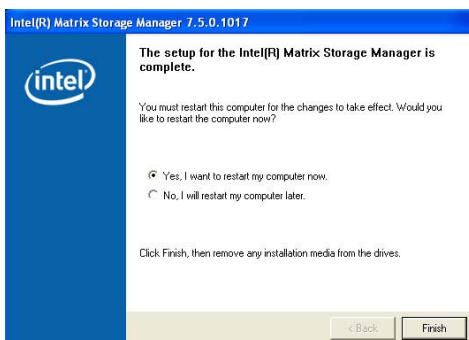

AHCI For F6 During Windows Setup Floppy Driver

You need to prepare an AHCI driver floppy diskette that you will need when you install the AHCI driver during Windows XP installation.

1. Click "AHCI For F6 During Windows Setup Floppy Driver" on the main menu.

Windows Explorer will appear showing the locations of the installation files.

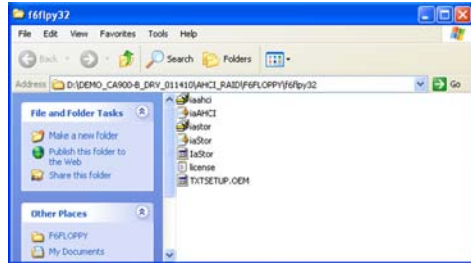

2. Click the Edit menu then click "Select All".
3. Insert a blank formatted floppy diskette into a floppy disk drive.

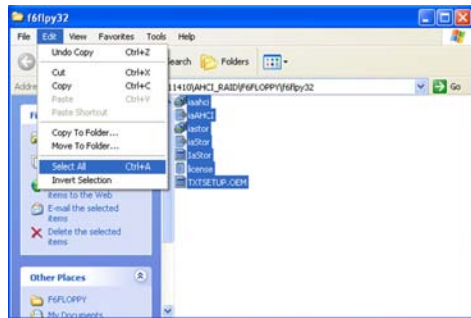

4. Right click on the files, select "Send To" and then select "3½ Floppy (A:)".

The system will copy the selected files into the diskette.

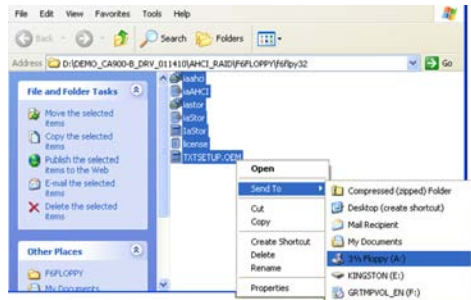

Installing the AHCI Driver During Windows XP Installation

The AHCI driver must be installed during Windows XP installation. This is required in order to be able to install the operating system onto a hard drive that is configured in AHCI mode.

1. When you insert the operating system's installation disc into an optical drive, the message **Press any key to boot from CD** will appear. Press Enter.
2. The message **Setup is inspecting your computer's hardware configuration** will appear.
3. Press **F6** when prompted in the status line with the "Press F6 if you need to install a third party SCSI or RAID driver" message.
4. Press **S** to "Specify Additional Device".
4. Insert the floppy disk, containing the AHCI driver, into a floppy drive.
5. Select **Intel(R) ICH8M-E/M SATA AHCI Controller** then press Enter.

You have successfully installed the driver. However you must continue installing the OS. Leave the floppy disk in the floppy drive until the system reboots itself because Windows setup will need to copy the files again from the floppy disk to the Windows installation folders. After Windows setup has copied these files again, remove the floppy diskette so that Windows setup can reboot as needed.

Infinion TPM Driver

To install, click “Infinion TPM Driver” on the main menu.

1. The setup program is preparing to install the driver.

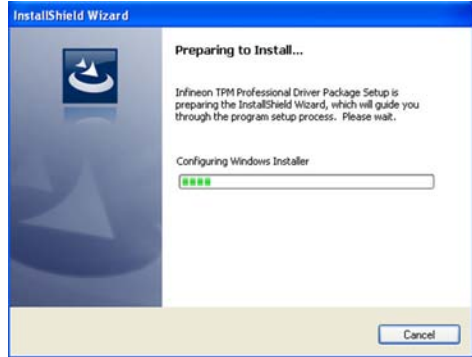

2. The driver has been successfully installed. Click Finish.



Infineon TPM Utility

To install, click "Infineon TPM Utility" on the main menu.

1. TPM requires installing the Microsoft Visual C++ package prior to installing the utility. Click Install.

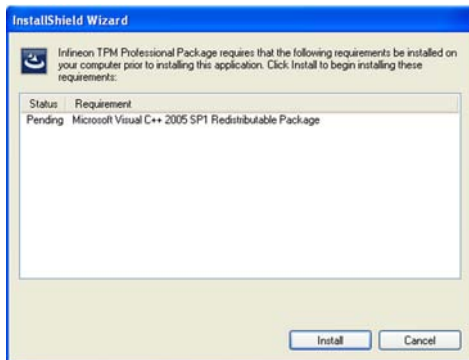

2. The setup program is currently installing the Microsoft Visual C++ package.

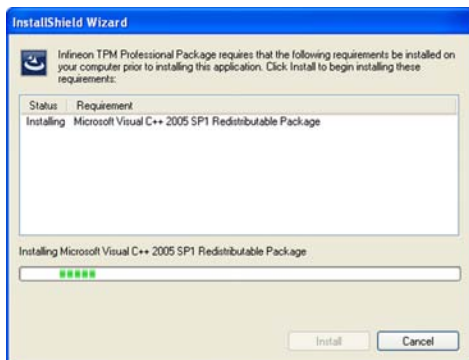

3. The setup program is now ready to install the utility. Click Next.



- Click "I accept the terms in the license agreement" and then click "Next".

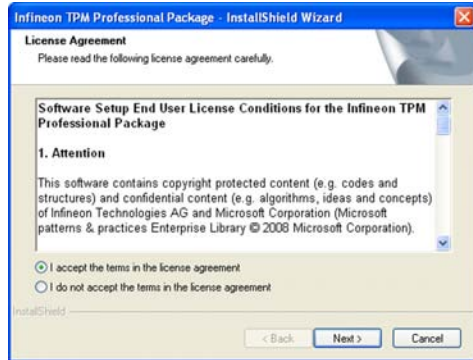

- Enter the necessary information and then click Next.

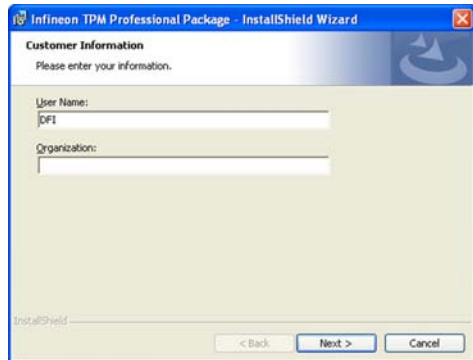

- Select a setup type and then click Next.



- Click Install.

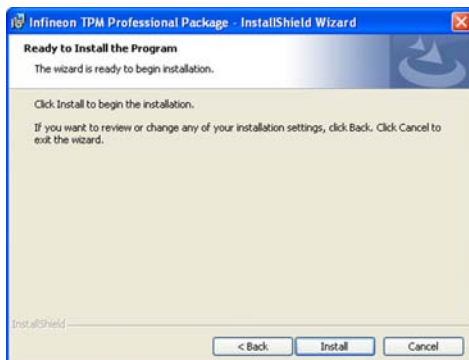

- Click Finish.



Adobe Acrobat Reader 9.3

To install the reader, click “Adobe Acrobat Reader 9.3” on the main menu.

1. Click Next to install to the destination folder or click Change Destination folder to select another folder.



2. Click Install to begin installation.

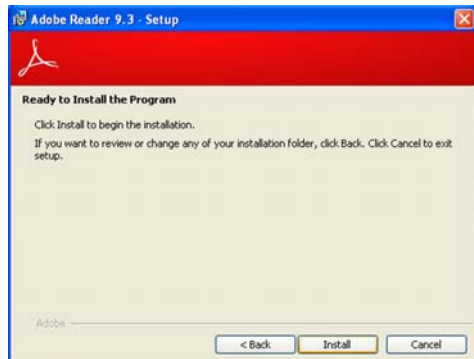

3. Click Finish to exit installation.

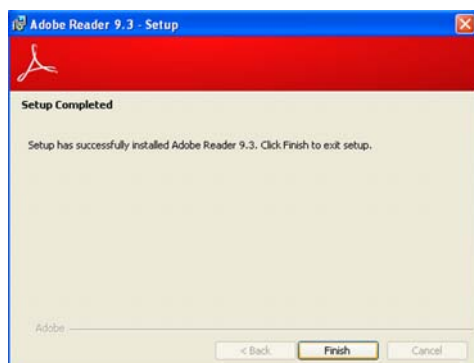

Appendix A - NLITE and AHCI Installation Guide

nLite

nLite is an application program that allows you to customize your XP installation disc by integrating the RAID/AHCI drivers into the disc. By using nLite, the F6 function key usually required during installation is no longer needed.



Note:

The installation steps below are based on nLite version 1.4.9. Installation procedures may slightly vary if you're using another version of the program.

1. Download the program from nLite's official website.

<http://www.nliteos.com/download.html>

2. Install nLite.



Important:

Due to it's coding with Visual.Net, you may need to first install .NET Framework prior to installing nLite.

3. Download relevant RAID/AHCI driver files from Intel's website. The drivers you choose will depend on the operating system and chipset used by your computer.

The downloaded driver files should include iaahci.cat, iaAHCI.inf, iastor.cat, iaStor.inf, IaStor.sys, license.txt and TXTSETUP.OEM.

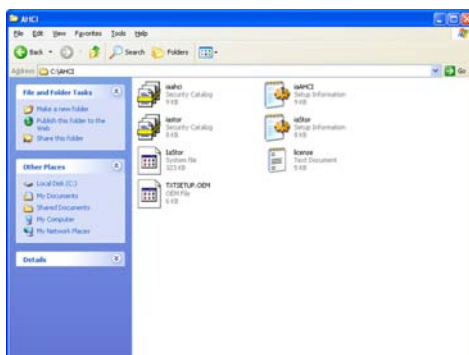

4. Insert the XP installation disc into an optical drive.
5. Launch nLite. The Welcome screen will appear. Click **Next**.

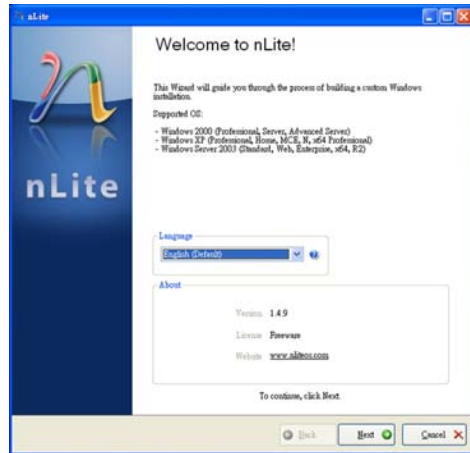

6. Click **Next** to temporarily save the Windows installation files to the designated default folder.

If you want to save them in another folder, click **Browse**, select the folder and then click **Next**.

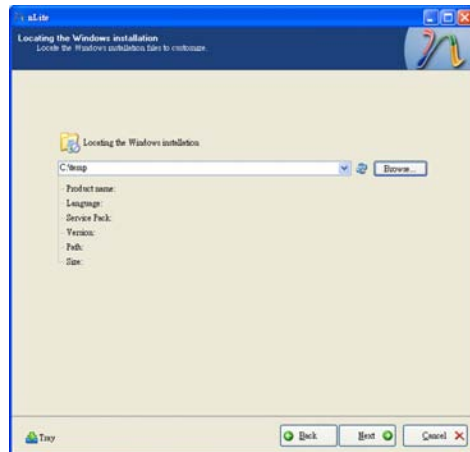

7. Click **Next**.

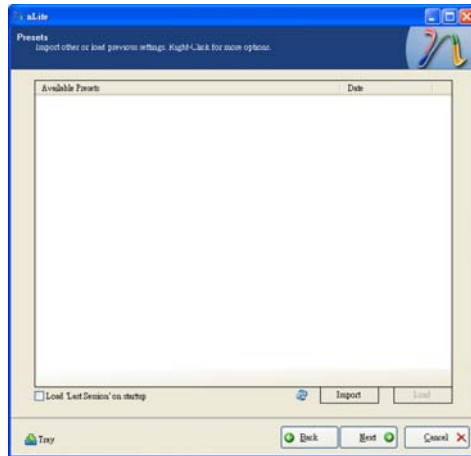

8. In the Task Selection dialog box, click **Drivers** and **Bootable ISO**. Click **Next**.

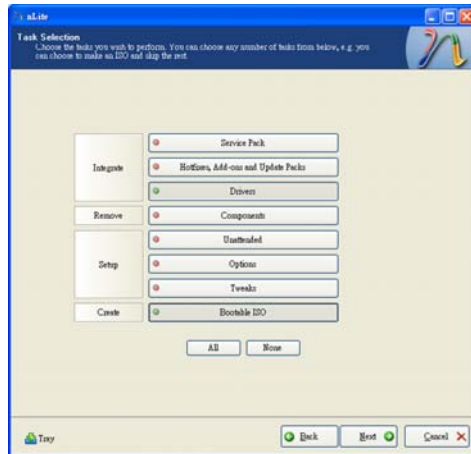

- Click **Insert** and then select **Multiple driver folder** to select the drivers you will integrate. Click **Next**.

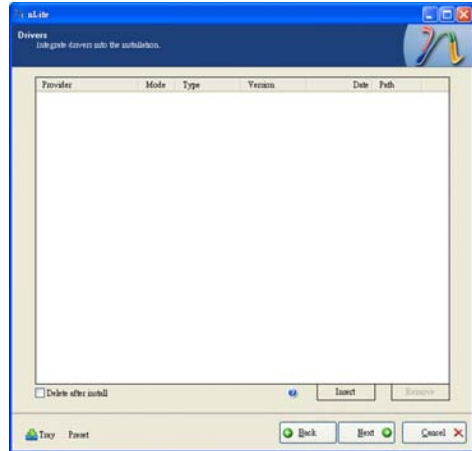

- Select only the drivers appropriate for the Windows version that you are using and then click **OK**.

Integrating 64-bit drivers into 32-bit Windows or vice versa will cause file load errors and failed installation.

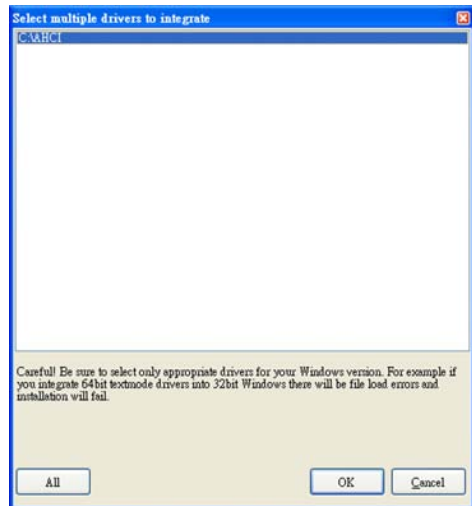

13. The program is currently integrating the drivers and applying changes to the installation.

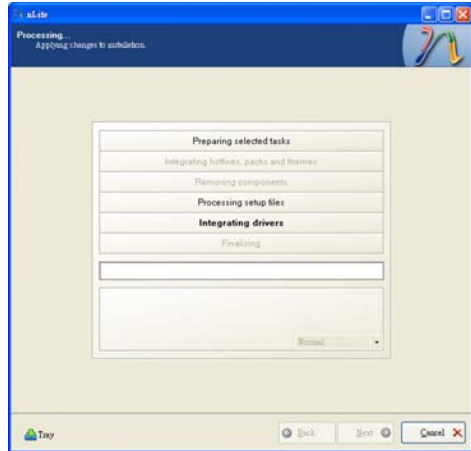

14. When the program is finished applying the changes, click **Next**.

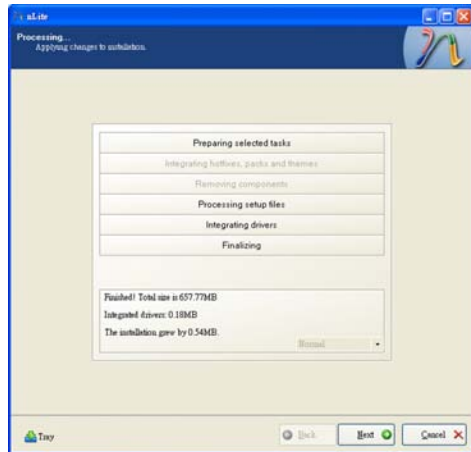

- To create an image, select the **Create Image** mode under the General section and then click **Next**.

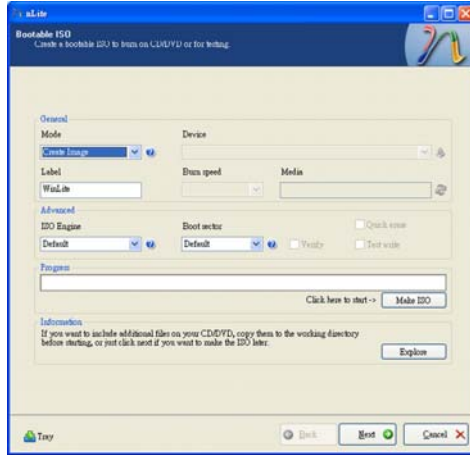

- Or you can choose to burn it directly to a disc by selecting the **Direct Burn** mode under the General section.

Select the optical device and all other necessary settings and then click

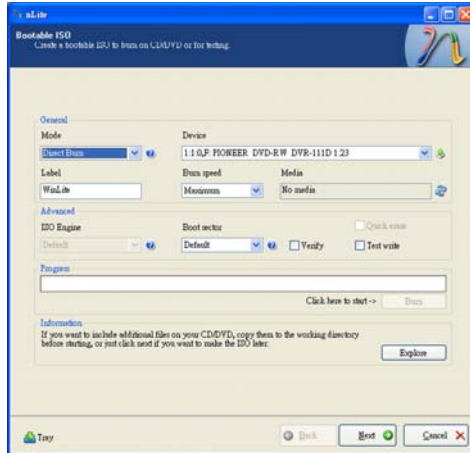

17. You have finished customizing the Windows XP installation disc. Click **Finish**.

Enter the BIOS utility to configure the SATA controller to RAID/AHCI. You can now install Windows XP.

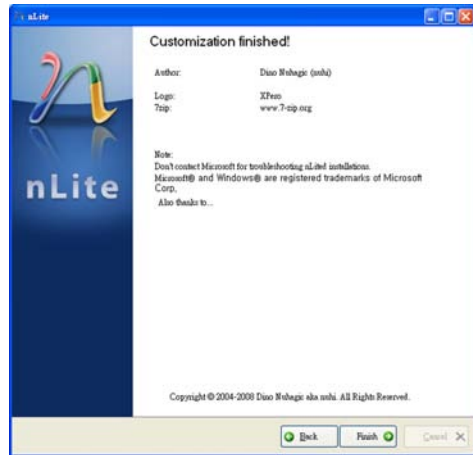

AHCI

The installation steps below will guide you in configuring your SATA drive to AHCI mode.

1. Enter the BIOS utility and configure the SATA controller to IDE mode.
2. Install Windows XP but do not press F6.
3. Download relevant RAID/AHCI driver files supported by the motherboard chipset from Intel's website.

Transfer the downloaded driver files to C:\AHCI.

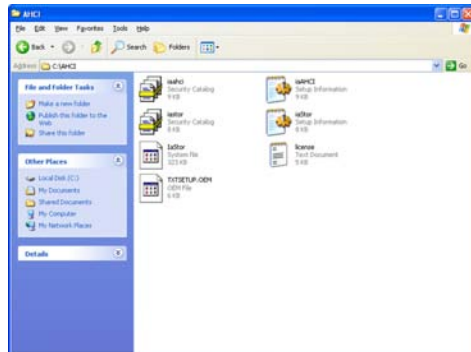

4. Open Device Manager and right click on one of the Intel Serial ATA Storage Controllers, then select **Update Driver**.

If the controller you selected did not work, try selecting another one.

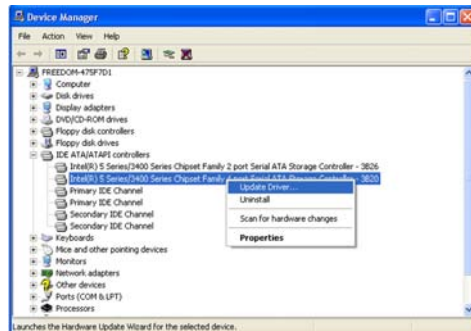

- In the Hardware Update Wizard dialog box, select **“No, not this time”** then click **Next**.



- Select **“Install from a list or specific location (Advanced)”** and then click **Next**.

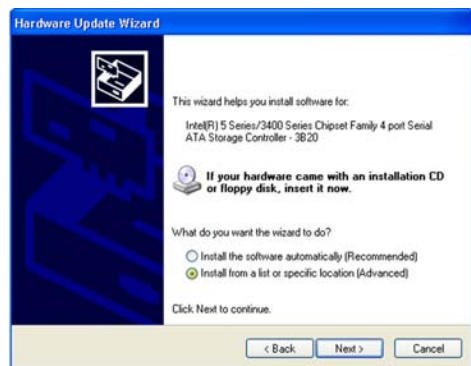

- Select **“Don't search. I will choose the driver to install”** and then click **Next**.

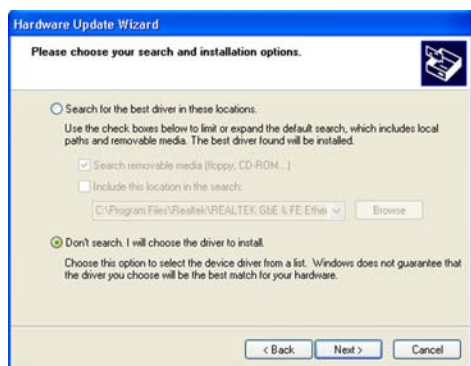

- Click "Have Disk".

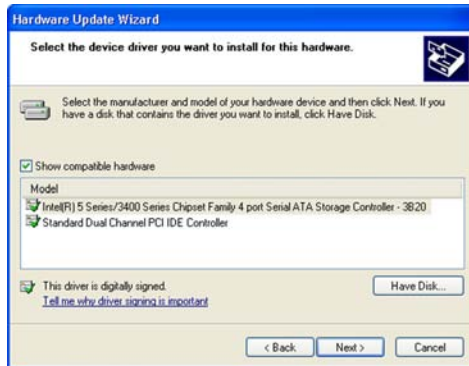

- Select C:\AHCI\iaAHCI.inf and then click **Open**.



- Select the appropriate AHCI Controller of your hardware device and then click **Next**.

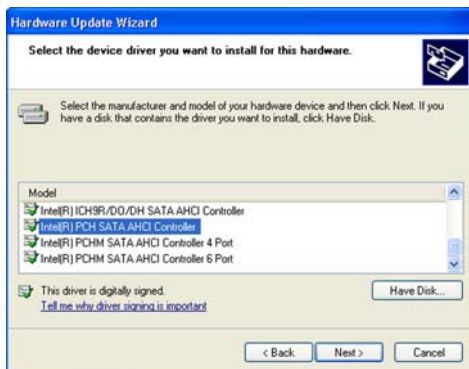

11. A warning message appeared because the selected SATA controller did not match your hardware device.

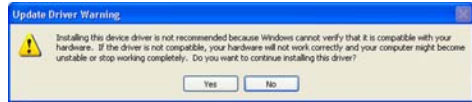

Ignore the warning and click **Yes** to proceed.

12. Click **Finish**.



13. The system's settings have been changed. Windows XP requires that you restart the computer. Click **Yes**.



14. Enter the BIOS utility and modify the SATA controller from IDE to AHCI. By doing so, Windows will work normally with the SATA controller that is in AHCI mode.

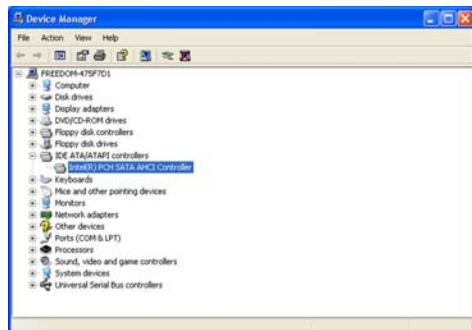

Appendix B - Watchdog Timer

Watchdog Timer

The following parameters are references for setting the time interval of the Watchdog Timer function. The system will regularly be “cleared” according to the set time interval. If the system hangs or fails to function, it will also reset according to the time interval so that your system will continue to operate.

```
.model small
.386

;-----
;Port defination
;-----
SuperIo_CFG_Port EQU 2Eh ;Super I/O Config port. (2Eh/4Eh)
SuperIo_DAT_Port EQU SuperIo_CFG_Port + 1

WDT_Counter EQU 10 ; 1 to 255 (Sec./Min), 0 means disabled

mSuperio_Enter_Config Macro
    mov dx, SuperIo_CFG_Port
    mov al, 87h
    out dx, al
    NEWIODELAY
    out dx, al
endM

mSuperio_Exit_Config Macro
    mov dx, SuperIo_CFG_Port
    mov al, 0AAh
    out dx, al
endM

mSuperio_GetSet_Reg Macro RegIndex, AndMask, OrValue
    mov dx, SuperIo_CFG_Port
    mov al, RegIndex
    out dx, al
    NEWIODELAY
    mov dx, SuperIo_DAT_Port
    in al, dx
    NEWIODELAY
    mov ah, al
    and al, AndMask
    or al, OrValue
    out dx, al
    NEWIODELAY
endM

mSuperio_Get_Reg Macro RegIndex
    mov dx, SuperIo_CFG_Port
    mov al, RegIndex
    out dx, al
```

```

        NEWIODELAY
        mov     dx, SuperIo_DAT_Port
        in     al, dx
        NEWIODELAY
endM

mSuperio_LDN_Select      Macro    LDN
        mSuperio_Set_Reg 07h, LDN
endM

mSuperio_Set_Reg Macro RegIndex, SetValue
        mov     dx, SuperIo_CFG_Port
        mov     al, RegIndex
        out    dx, al
        NEWIODELAY
        mov     dx, SuperIo_DAT_Port
        mov     al, SetValue
        out    dx, al
        NEWIODELAY
endM

NEWIODELAY      Macro
        out     0EBh, al ;Dummy I/O output for delay
endM

.code

start:
        call    W83627Hx_WDT

        mov     ah, 4ch
        int     21h

W83627Hx_WDT Proc near
;LDN8
;CRF5[3] :RW 0/1 = WDTO Second/Minute
;CRF5[2] :RW 0/1 = Keyboard Reset Low/High when WDTO Timeout

;CRF6[7:0]:RW 00h = Disable , 01h~0FFh = 1~255 Sec/Min.

;CRF7[7] :RW 0/1 = Disable/Enable Mouse interrupt reset WDTO counting.
;CRF7[6] :RW 0/1 = Disable/Enable Keyboard interrupt reset WDTO counting.
;CRF7[5] :WO 1 = Force WDTO time out(Auto clear).
;CRF7[4] :RW 0/1 = WDTO time status TimeOut/Counting.
;CRF7[3:0]:RW 0~7 = Low IRQ for WDTO (Typical is 2, means SMI).

        mSuperio_Enter_Config

        mSuperio_LDN_Select 08h

```

```
; PLED mode register, WDTO time unit as second, Keyboard reset when WDTO  
time out
```

```
    mSuperio_GetSet_Reg 0F5h, 11110111b, 00000100b
```

```
; , Disable MS/KB interrupt reset WDTO counting, IRQ2 for WDTO
```

```
    mSuperio_GetSet_Reg 0F7h, 11111111b, 11000010b
```

```
; , WDTO Time out Value
```

```
    mSuperio_Set_Reg 0F6h, WDT_Counter
```

```
mSuperio_Exit_Config
```

```
@@:
```

```
    ret
```

```
W83627Hx_WDT    endP
```

```
end start
```

Appendix C - System Error Message

When the BIOS encounters an error that requires the user to correct something, either a beep code will sound or a message will be displayed in a box in the middle of the screen and the message, PRESS F1 TO CONTINUE, CTRL-ALT-ESC or DEL TO ENTER SETUP, will be shown in the information box at the bottom. Enter Setup to correct the error.

Error Messages

One or more of the following messages may be displayed if the BIOS detects an error during the POST. This list indicates the error messages for all Awards BIOSes:

CMOS BATTERY HAS FAILED

The CMOS battery is no longer functional. It should be replaced.



Important

Danger of explosion if battery incorrectly replaced. Replace only with the same or equivalent type recommended by the manufacturer. Dispose of used batteries according to the battery manufacturer's instructions.

CMOS CHECKSUM ERROR

Checksum of CMOS is incorrect. This can indicate that CMOS has become corrupt. This error may have been caused by a weak battery. Check the battery and replace if necessary.

DISPLAY SWITCH IS SET INCORRECTLY

The display switch on the motherboard can be set to either monochrome or color. This indicates the switch is set to a different setting than indicated in Setup. Determine which setting is correct, either turn off the system and change the jumper or enter Setup and change the VIDEO selection.

Hard Disk(s) fail (80)

HDD reset failed.

Hard Disk(s) fail (40)

HDD controller diagnostics failed.

Hard Disk(s) fail (20)

HDD initialization error.

Hard Disk(s) fail (10)

Unable to recalibrate fixed disk.

Hard Disk(s) fail (08)

Sector Verify failed.

Keyboard is locked out - Unlock the key

The BIOS detects that the keyboard is locked. Keyboard controller is pulled low.

Keyboard error or no keyboard present

Cannot initialize the keyboard. Make sure the keyboard is attached correctly and no keys are being pressed during the boot.

Manufacturing POST loop

System will repeat POST procedure infinitely while the keyboard controller is pulled low. This is also used for the M/B burn in test at the factory.

BIOS ROM checksum error - System halted

The checksum of ROM address F0000H-FFFFFH is bad.

Memory test fail

The BIOS reports memory test fail if the memory has error(s).

Appendix D - Troubleshooting

Troubleshooting Checklist

This chapter of the manual is designed to help you with problems that you may encounter with your personal computer. To efficiently troubleshoot your system, treat each problem individually. This is to ensure an accurate diagnosis of the problem in case a problem has multiple causes.

Some of the most common things to check when you encounter problems while using your system are listed below.

1. The power switch of each peripheral device is turned on.
2. All cables and power cords are tightly connected.
3. The electrical outlet to which your peripheral devices are connected is working. Test the outlet by plugging in a lamp or other electrical device.
4. The monitor is turned on.
5. The display's brightness and contrast controls are adjusted properly.
6. All add-in boards in the expansion slots are seated securely.
7. Any add-in board you have installed is designed for your system and is set up correctly.

Monitor/Display

If the display screen remains dark after the system is turned on:

1. Make sure that the monitor's power switch is on.
2. Check that one end of the monitor's power cord is properly attached to the monitor and the other end is plugged into a working AC outlet. If necessary, try another outlet.
3. Check that the video input cable is properly attached to the monitor and the system's display adapter.
4. Adjust the brightness of the display by turning the monitor's brightness control knob.

The picture seems to be constantly moving.

1. The monitor has lost its vertical sync. Adjust the monitor's vertical sync.
2. Move away any objects, such as another monitor or fan, that may be creating a magnetic field around the display.
3. Make sure your video card's output frequencies are supported by this monitor.

The screen seems to be constantly wavering.

1. If the monitor is close to another monitor, the adjacent monitor may need to be turned off. Fluorescent lights adjacent to the monitor may also cause screen wavering.

Power Supply

When the computer is turned on, nothing happens.

1. Check that one end of the AC power cord is plugged into a live outlet and the other end properly plugged into the back of the system.
2. Make sure that the voltage selection switch on the back panel is set for the correct type of voltage you are using.
3. The power cord may have a "short" or "open". Inspect the cord and install a new one if necessary.

Hard Drive

Hard disk failure.

1. Make sure the correct drive type for the hard disk drive has been entered in the BIOS.
2. If the system is configured with two hard drives, make sure the bootable (first) hard drive is configured as Master and the second hard drive is configured as Slave. The master hard drive must have an active/bootable partition.

Excessively long formatting period.

If your hard drive takes an excessively long period of time to format, it is likely a cable connection problem. However, if your hard drive has a large capacity, it will take a longer time to format.

Serial Port

The serial device (modem, printer) doesn't output anything or is outputting garbled characters.

1. Make sure that the serial device's power is turned on and that the device is on-line.
2. Verify that the device is plugged into the correct serial port on the rear of the computer.
3. Verify that the attached serial device works by attaching it to a serial port that is working and configured correctly. If the serial device does not work, either the cable or the serial device has a problem. If the serial device works, the problem may be due to the onboard I/O or the address setting.
4. Make sure the COM settings and I/O address are configured correctly.

Keyboard

Nothing happens when a key on the keyboard was pressed.

1. Make sure the keyboard is properly connected.
2. Make sure there are no objects resting on the keyboard and that no keys are pressed during the booting process.

System Board

1. Make sure the add-in card is seated securely in the expansion slot. If the add-in card is loose, power off the system, re-install the card and power up the system.
2. Check the jumper settings to ensure that the jumpers are properly set.
3. Verify that all memory modules are seated securely into the memory sockets.
4. Make sure the memory modules are in the correct locations.
5. If the board fails to function, place the board on a flat surface and seat all socketed components. Gently press each component into the socket.
6. If you made changes to the BIOS settings, re-enter setup and load the BIOS defaults.